

*IBM Token-Ring PCI Family Adapter
User's Guide*

August 26, 1999

IBM Token-Ring PCI Family Adapter



User's Guide

Note

Before using this information and the product it supports, be sure to read "Safety Information" on page ix and "Appendix H. Notices" on page 77.

Second Edition (August 1999)

This edition applies to the IBM Token-Ring PCI Family Adapter.

You can submit comments online to <http://www.networking.ibm.com/support/feedback.nsf/docsoverall>.

© **Copyright International Business Machines Corporation 1998, 1999. All rights reserved.**

US Government Users Restricted Rights – Use, duplication or disclosure restricted by GSA ADP Schedule Contract with IBM Corp.

Contents

About This Manual	vii
Who Should Read This Manual	vii
How This Manual Is Organized	vii
Related Information	viii
Safety Information	ix
Telecommunications Safety Requirements in the United Kingdom	xiii
Statement of Compliance with the United Kingdom Telecommunications Act 1984	xiii
Chapter 1. The IBM Token-Ring PCI Family Adapters	1
Adapter Installation Checklist	1
Environment Limitations on Number of Adapters	2
Package Contents	2
Automatic Configuration and Power Interface (ACPI)	2
Chapter 2. Installing the Adapter Hardware	5
Installing Wake on LAN Cables for the IBM High-Speed 100/16/4 Token-Ring PCI Adapter	5
Installing Wake on LAN Cables for IBM 16/4 Token-Ring PCI Adapter 2 with Wake on LAN	7
Installing Your Adapter without the Wake on LAN Feature	8
Adapter Cable	8
Chapter 3. Software Installation	11
Novell NetWare 3.12 Server	12
Server Driver Installation in New NetWare 3.12 Server	13
Novell NetWare 4.11 Server	16
Server Driver Installation in New NetWare 4.11 Server	16
Server Driver Installation in Existing NetWare 4.11 Server	17
Novell NetWare 5.0 Server	19
Server Driver Installation During NetWare 5.0 Server Installation	19
Server Driver Installation in Existing NetWare 5.0 Server	21
Novell Client DOS/Windows 3.1x	21
OS/2 NDIS 2 Device Driver Using MPTS	22
OS/2 NDIS 2 Device Driver Using Other Installation Programs	23
OS/2 Novell NetWare Requester	24
DOS NDIS 2	25
DOS Novell NetWare Requester (16-bit)	25
Windows NT™ Version 3.51	26
Windows NT Version 4.0	27
Windows 95	28
If Windows 95 Retail is Already Installed	29
If Windows 95 OSR2 Is Already Installed	29
First-Time Installation of Windows 95 with the IBM Token-Ring PCI Family Adapter	30
Windows 98	32
Installing the Updated Driver	32
If Windows 98 Is Already Installed	33
Remote Unattended Installation of Windows 95, Windows 98 and Windows NT	34
Novell IntranetWare Client for Windows NT	35
Novell Client for Windows 95	35
Windows for Workgroups with NDIS 3	36

Chapter 4. Problem Solving	37
Start of Troubleshooting Process	37
Solving an Adapter Communication Problem	37
Tech Tips and Frequently Asked Questions	38
Other Performance Enhancements	38
PCSETUP	38
DOS, Novell, Windows, or Windows 95 (adapter driver not in CONFIG.SYS)	38
DOS, Novell, Windows, or Windows 95 (adapter driver in CONFIG.SYS)	38
OS/2	38
Windows NT	39
Solving Problems with Driver Installation	39
Understanding the Adapter LEDs and Labels	39
Understanding the Adapter Labels	41
Adapter Diagnostics.	42
Questions, Problems?	43
World Wide Web	43
IBM Product Support	43
Appendix A. CD-ROM Content and Software Packages	45
Software Packages	45
Diskette Images	46
Product Documentation	46
Appendix B. About Alert on LAN	49
Features	49
Appendix C. NDIS 2 Device Driver Parameters	51
Appendix D. NDIS 2 Device Driver Messages	57
Appendix E. Novell NetWare Server and LAN Client Driver Parameters	63
Appendix F. Novell NetWare Server and LAN Client Driver Messages	69
Appendix G. Novell NetWare DOS ODI Driver Parameters	75
Appendix H. Notices	77
Trademarks.	78
Notice to Users of Online Versions of This Book	78
Electronic Emission Notices.	78
Federal Communications Commission (FCC) Statement	79
Other Electronic Emission Notices for STP Media.	79
European Norm (EN) Statement	80
Hinweis zur Elektromagnetischen Verträglichkeit (EMVG)	80
Japanese Voluntary Control Council for Interference (VCCI) Statement	80
Other Electronic Emission Notices for UTP Media.	80
Federal Communications Commission (FCC) Statement	81
European Norm (EN) Statement	81
Japanese Voluntary Control Council for Interference (VCCI) Statement	82
Power Cord Notices for UTP Media	82
IBM License Agreement for Productivity Aids	83
IF YOU DOWNLOAD OR USE THIS PROGRAM YOU AGREE TO THESE TERMS.	84
NetWare Network Computing Products from IBM	85
Protection and Security	86
Statement of Limited Warranty	86

Glossary of Terms and Abbreviations	89
Index	95

About This Manual

This manual contains the information you need to install and use your adapter.

Unless specified, all references to the IBM Token-Ring PCI Family Adapter in this book apply to the following adapters:

- IBM 16/4 Token-Ring PCI Adapter 2
- IBM 16/4 Token-Ring PCI Adapter 2 with Wake on LAN
- IBM High-Speed 100/16/4 Token-Ring PCI Adapter

Also on this CD-ROM are the installation aids, device drivers, and documentation for the adapters.

Who Should Read This Manual

This manual is intended for use by network administrators and other end users of the IBM Token-Ring PCI Family Adapters.

How This Manual Is Organized

“Chapter 1. The IBM Token-Ring PCI Family Adapters” on page 1 describes the adapters covered in this manual, gives a checklist for installation, and describes some of the features of the adapters.

“Chapter 2. Installing the Adapter Hardware” on page 5 describes the procedure for installing the adapter into your computer.

“Chapter 3. Software Installation” on page 11 describes the procedure for software installation for a number of network operating environments.

“Chapter 4. Problem Solving” on page 37 describes troubleshooting procedures and fixes that might be needed for your environment.

“Appendix A. CD-ROM Content and Software Packages” on page 45 describes the files that are on the IBM Token-Ring PCI Family Adapter CD-ROM.

“Appendix B. About Alert on LAN” on page 49 describes the Alert on LAN function.

“Appendix C. NDIS 2 Device Driver Parameters” on page 51 lists the NDIS 2 parameters, describes their usage, and lists their values.

“Appendix D. NDIS 2 Device Driver Messages” on page 57 lists the NDIS 2 system messages, explains the meaning, and lists user actions.

“Appendix E. Novell NetWare Server and LAN Client Driver Parameters” on page 63 lists the Novell and LAN Client parameters, describes their usage, and lists their values.

“Appendix F. Novell NetWare Server and LAN Client Driver Messages” on page 69 lists the Novell and LAN Client messages, explains the meaning, and lists user actions.

“Appendix G. Novell NetWare DOS ODI Driver Parameters” on page 75 lists the Novell parameters, describes their usage, and lists their values.

“Appendix H. Notices” on page 77 lists the legal notices required for the IBM Token-Ring PCI Family Adapters.

Related Information

Refer to these publications for additional information:

- *IBM Token-Ring Adapter Features*, available on the IBM Token-Ring PCI Family Adapter CD-ROM
- *ISO/IEC 8802-5:1998 Base Standard 4/16 HDX and related amendments*
- *IBM Token-Ring Network Problem Determination Guide*, SX27-3710
- *IBM LAN Technical Reference IEEE 802.2 and NETBIOS API*, SC30-3587
- *IBM Transmission Control Protocol/Internet Protocol Version 2.1 for DOS: Programmer's Reference*, SC31-7046
- *LAN Adapter and Protocol Support Configuration Guide*, S96F-8489
- *MPTS/2 Configuration Guide*, S10H-9693
- *IBM LAN Server Command and Utilities*, S10H-9686
- *Guide to LAN Server Books*, S10H-9688
- *DOS LAN Services and User's Guide*, S10H-9684
- *Microsoft LAN Manager Installation and Configuration Guide*
- *Microsoft Windows NT System Guide*
- *Novell Workstation for DOS and MS Windows*
- Novell NetWare installation and system administration manuals appropriate to the version of Novell NetWare you have installed
- IBM Networking home page on the World Wide Web:
www.ibm.com/networking

Safety Information



Danger: Before you begin to install this product, read the safety information in *Caution: Safety Information—Read This First*, SD21-0030. This booklet describes safe procedures for cabling and plugging in electrical equipment.



Gevaar: Voordat u begint met de installatie van dit produkt, moet u eerst de veiligheidsinstructies lezen in de brochure *PAS OP! Veiligheidsinstructies—Lees dit eerst*, SD21-0030. Hierin wordt beschreven hoe u elektrische apparatuur op een veilige manier moet bekabelen en aansluiten.



Perigo: Antes de começar a instalar este produto, leia as informações de segurança contidas em *Cuidado: Informações Sobre Segurança—Leia Isto Primeiro*, SD21-0030. Esse folheto descreve procedimentos de segurança para a instalação de cabos e conexões em equipamentos elétricos.



危險：安裝本產品之前，請先閱讀
"Caution: Safety Information—Read
This First" SD21-0030 手冊中所提
供的安全注意事項。這本手冊將會說明
使用電器設備的纜線及電源的安全程序。



Opasnost: Prije nego što počnete sa instalacijom produkta, pročitajte naputak o pravilima o sigurnom rukovanju u
Upozorenje: Pravila o sigurnom rukovanju - Prvo pročitaj ovo, SD21-0030. Ovaj priručnik opisuje sigurnosne postupke za priključivanje kabela i priključivanje na električno napajanje.



Upozornění: než zahájíte instalaci tohoto produktu, přečtěte si nejprve bezpečnostní informace v pokynech „Bezpečnostní informace“ č. 21-0030. Tato brožurka popisuje bezpečnostní opatření pro kabeláž a zapojení elektrického zařízení.



Fare! Før du installerer dette produkt, skal du læse sikkerhedsforskrifterne i *NB: Sikkerhedsforskrifter—Læs dette først* SD21-0030. Vejledningen beskriver den fremgangsmåde, du skal bruge ved tilslutning af kabler og udstyr.



Gevaar Voordat u begint met het installeren van dit produkt, dient u eerst de veiligheidsrichtlijnen te lezen die zijn vermeld in de publikatie *Caution: Safety Information - Read This First*, SD21-0030. In dit boekje vindt u veilige procedures voor het aansluiten van elektrische apparatuur.



VAARA: Ennen kuin aloitat tämän tuotteen asennuksen, lue julkaisussa *Varoitus: Turvaohjeet—Lue tämä ensin*, SD21-0030, olevat turvaohjeet. Tässä kirjasessa on ohjeet siitä, miten sähkölaitteet kaapeloidaan ja kytketään turvallisesti.



Danger : Avant d'installer le présent produit, consultez le livret *Attention : Informations pour la sécurité — Lisez-moi d'abord*, SD21-0030, qui décrit les procédures à respecter pour effectuer les opérations de câblage et brancher les équipements électriques en toute sécurité.



Vorsicht: Bevor mit der Installation des Produktes begonnen wird, die Sicherheitshinweise in *Achtung: Sicherheitsinformationen—Bitte zuerst lesen*, IBM Form SD21-0030. Diese Veröffentlichung beschreibt die Sicherheitsvorkehrungen für das Verkabeln und Anschließen elektrischer Geräte.



Κίνδυνος: Πριν ξεκινήσετε την εγκατάσταση αυτού του προϊόντος, διαβάστε τις πληροφορίες ασφάλειας στο φυλλάδιο *Caution: Safety Information-Read this first*, SD21-0030. Στο φυλλάδιο αυτό περιγράφονται οι ασφαλείς διαδικασίες για την καλωδίωση των ηλεκτρικών συσκευών και τη σύνδεσή τους στην πρίζα.



Vigyázat: Mielőtt megkezdi a berendezés üzembe helyezését, olvassa el a *Caution: Safety Information— Read This First*, SD21-0030 könyvecskében leírt biztonsági információkat. Ez a könyv leírja, milyen biztonsági intézkedéseket kell megtenni az elektromos berendezés huzalozásakor illetve csatlakoztatásakor.



Pericolo: prima di iniziare l'installazione di questo prodotto, leggere le informazioni relative alla sicurezza riportate nell'opuscolo *Attenzione: Informazioni di sicurezza — Prime informazioni da leggere* in cui sono descritte le procedure per il cablaggio ed il collegamento di apparecchiature elettriche.



危険： 導入作業を開始する前に、安全に関する小冊子SD21-0030 の「最初にお読みください」(Read This First)の項をお読みください。
この小冊子は、電気機器の安全な配線と接続の手順について説明しています。



위험: 이 제품을 설치하기 전에 반드시 "주의: 안전 정보-시작하기 전에" (SD21-0030) 에 있는 안전 정보를 읽으십시오.



ОПАСНОСТ

Пред да почнете да го инсталирате овој продукт, прочитајте ја информацијата за безбедност:
"Предупредување: Информација за безбедност: Прочитајте го прво ова", SD21-0030.
Оваа брошура опишува безбедносни процедури за каблирање и вклучување на електрична опрема.



Fare: Før du begynner å installere dette produktet, må du lese sikkerhetsinformasjonen i *Advarsel: Sikkerhetsinformasjon — Les dette først*, SD21-0030 som beskriver sikkerhetsrutinene for kabling og tilkobling av elektrisk utstyr.



Uwaga:
Przed rozpoczęciem instalacji produktu należy zapoznać się z instrukcją:
"Caution: Safety Information - Read This First", SD21-0030.
Zawiera ona warunki bezpieczeństwa przy podłączaniu do sieci elektrycznej i eksploatacji.



Perigo: Antes de iniciar a instalação deste produto, leia as informações de segurança *Cuidado: Informações de Segurança — Leia Primeiro*, SD21-0030. Este documento descreve como efectuar, de um modo seguro, as ligações eléctricas dos equipamentos.



ОСТОРОЖНО: Прежде чем устанавливать этот продукт, прочтите Инструкцию по технике безопасности в документе "Внимание: Инструкция по технике безопасности -- Прочсть в первую очередь", SD21-0030. В этой брошюре описаны безопасные способы каблирования и подключения электрического оборудования.



Nebezpečnostvo: Pred inštaláciou výrobku si prečítajte bezpečnosté predpisy v
Výstraha: Bezpečnosté predpisy - Prečítaj ako prvý, SD21-0030. V tejto brožúrke sú opísané bezpečnosté postupy pre pripojenie elektrických zariadení.



Pozor: Preden zaènete z instalacijo tega produkta preberite poglavje: "Opozorilo: Informacije o varnem rokovanju-preberi pred uporabo," SD21-0030. To poglavje opisuje pravilne postopke za kabliiranje,



Peligro: Antes de empezar a instalar este producto, lea la información de seguridad en *Atención: Información de Seguridad — Lea Esto Primero*, SD21-0030. Este documento describe los procedimientos de seguridad para cablear y enchufar equipos eléctricos.



Varning — livsfara: Innan du börjar installera den här produkten bör du läsa säkerhetsinformationen i dokumentet *Varning: Säkerhetsföreskrifter— Läs detta först*, SD21-0030. Där beskrivs hur du på ett säkert sätt ansluter elektrisk utrustning.



危險：

開始安裝此產品之前，請先閱讀安全資訊。

注意：

請先閱讀 - 安全資訊 SD21-0030

此冊子說明插接電器設備之電纜線的安全程序。

Telecommunications Safety Requirements in the United Kingdom

This IBM product is made to high safety standards. It complies inherently with telecommunications safety standard BS 6301. It is not designed to provide protection from excessive voltages appearing externally at its interfaces. Therefore, when this product is connected to a public telecommunications network via any other equipment, and you connect to this product items not supplied by IBM United Kingdom Ltd., you must comply with mandatory telecommunications safety requirements.

Statement of Compliance with the United Kingdom Telecommunications Act 1984

This apparatus is approved under approval number NS/G/1234/J/100003 for indirect connections to the public telecommunications systems in the United Kingdom.

Chapter 1. The IBM Token-Ring PCI Family Adapters

This chapter describes the adapters, the contents of the adapter kits, and the other materials you will need to install the adapters.

It is important that you are familiar with the computer in which the adapter will be installed and the computer's operating system and network software.

The IBM Token-Ring PCI Family Adapters are 32-bit, bus-master, Token-Ring adapters for the PCI bus architecture. Their unique, high-quality filter design supports connection to a Token-Ring network that is wired with shielded twisted-pair (STP) or unshielded twisted-pair (UTP) cabling. The adapters can be used in PCI-compatible slots that operate at speeds up to 33 MHz.

Features of the IBM Token-Ring PCI Family Adapters include:

- Adapter management capability using SNMP and Desktop Management Interface (DMI) is available by using the LAN Adapter Management Agent. For an end-to-end management solution, the agent can be used in conjunction with the Nways[®] Workgroup Manager Version 1.1 or higher and Nways Manager for AIX[®] Version 1.2 or higher.
- Automatic ring-speed detection.
- Support for a wide variety of network operating systems and network applications.
- Support for full-duplex (FDX), Token-Ring LAN operation.
- Support for microcode update.
- Automatic configuration of I/O, memory, ROM space, and interrupt level by PCI BIOS on power-up.
- Can be plugged into either a half-size or full-size, 5-V or 3.3-V signaling, 32-bit or 64-bit PCI-bus slot.
- IBM 16/4 Token-Ring PCI Adapter 2 use less than 1 watt; IBM 16/4 Token-Ring PCI Adapter 2 with Wake on LAN uses 1.5 watts; IBM High-Speed 100/16/4 Token-Ring PCI Adapter uses less than 2 watts.

See *IBM Token-Ring Adapter Features* for information regarding the following features:

- DHCP
- Remote Program Load (RPL)
- IBM LAN Client
- LAN Adapter Management Agent
- Route Switching
- Class of Service
- Redundant NIC
- Performance Tuning

Adapter Installation Checklist

To install your adapter, complete the following steps in order. You might want to mark this page for easy retrieval or make a copy for reference.

1. Preparation

You will need:

The manual provided with your computer

The manual provided with your network operating system or network application

Your operating system and network application software

Check the shipping package contents list "Package Contents".

2. Install the hardware before installing the software. See Chapter 2. Installing the Adapter Hardware.
3. Install the adapter software. See Chapter 3. Software Installation.
4. Installation is now complete.

Environment Limitations on Number of Adapters

See the following table for the maximum number of adapters that can be supported by device driver type.

Device Driver	Maximum Number of adapters
Novell ODI OS/2 [®] Client	2
Novell ODI DOS Client	1
NDIS 2.0 DOS	1
LAN Client	1
SCO Unix	4

Package Contents

Following is a table which lists features on the IBM Token-Ring PCI Family Adapters.

Adapter	ACPI/PCI PM Feature	Legacy Wake on LAN [®] Feature	Alert on LAN [™] Feature	# WOL Cables
IBM 16/4 Token-Ring PCI Adapter 2	X			0
IBM 16/4 Token-Ring PCI Adapter 2 with Wake on LAN	X	X	X	2
IBM High-Speed 100/16/4 Token-Ring PCI Adapter	X	X		2+wrap plug

Terms mentioned in the table are described in the following sections.

Automatic Configuration and Power Interface (ACPI)

If your computer supports ACPI, then it has built-in energy-saving capabilities. When ACPI is enabled (usually through the computer BIOS settings), the operating system is allowed to control the power management features of your computer. Not all operating systems support ACPI BIOS mode. Refer to your operating system documentation to determine if ACPI is supported. Refer to your computer system documentation to determine if ACPI BIOS is offered and the method by which it can be enabled. The IBM Token-Ring PCI Family Adapters implement the PCI Bus Power Management Interface Specification (Version 1.0) which works together with ACPI. Under control of the operating system, the adapter (and the entire system) can be placed in various power-saving modes and be dynamically configured to look for network protocol-specific events. Upon detection of these events, the adapter can signal a wake-up condition which will bring the system to a fully-powered (operational) state.

Some systems might need to be configured through BIOS settings (configuration/setup utilities) to allow PCI devices to wake a system. Refer to your computer system documentation for automatic power-on feature settings (or PCI wake-up features).

Legacy Wake on LAN: adapters which support this feature have the ability to turn on a system that is powered off. The adapter has an additional cable that connects to the computer system which provides auxiliary power to the adapter. The adapter always has a source of power, even when the system is powered off (system power cord is connected to a live power outlet). When the system is powered off, the adapter automatically inserts into the network and looks for a special frame. This frame is commonly referred to as a magic packet. Upon detection of the magic packet, the adapter signals the system to turn on the power supply, thus turning on the computer system. The magic packet is a frame sent by another computer system usually running an application that provides remote system management.

Alert on LAN: This feature enables computers to send immediate alerts to network administrators when there are hardware or operating system failures, or evidence of tampering. The unique value add of Alert on LAN technology is its ability to generate these alerts, even if the system is powered off or the operating system is not yet loaded or both. The Alert on LAN cable also provides the Legacy Wake on LAN interface.

Intel LANDesk™ Client Manager Version 3.3 and IBM Asset Care management software provide a total solution. For more information, see “Appendix B. About Alert on LAN” on page 49.

Chapter 2. Installing the Adapter Hardware

The IBM Token-Ring PCI Family Adapter comes configured from the factory with RPL/DHCP and expansion ROM enabled.

If you want to change these settings, create the LANAIDC and Diagnostics diskette from the DIAGDISK.EXE image file. Boot your machine with this diskette and select the LANAIDC option from the startup menu. Enter **/h** at the LANAIDC command line prompt for a list of parameters.

1. Switch OFF the PC and all attached devices.

Note: In the U.K., by law, telephone line cables must be disconnected from the PC before the power cord.

2. Remove the power cord from the outlet.

Attention

Ensure that your PC is unplugged from the electrical outlet. Power is always supplied to the power connector that attaches to the Wake on LAN adapters, even when the system power switch is OFF.

3. Remove all cables from your PC. Label each cable for easier reconnection at the end of this procedure.
4. Follow the instructions provided in your PC manual for removing the cover or otherwise accessing the adapter slots and inserting the adapter.
5. Install the adapter according to the instructions for adapter installation in the manual that came with your PC.

Note: If you will be using the Wake on LAN feature, then depending on the orientation of the adapter to your computer, you might need to connect the Wake on LAN cable to your adapter before inserting the adapter into the slot in your computer.

6. If you are installing an adapter that does not support Wake on LAN, or if you do not want to install the Wake on LAN feature, go to “Installing Your Adapter without the Wake on LAN Feature” on page 8.

If you are installing the IBM 16/4 Token-Ring PCI Adapter 2 with Wake on LAN, go to “Installing Wake on LAN Cables for IBM 16/4 Token-Ring PCI Adapter 2 with Wake on LAN” on page 7.

If you are installing the IBM High-Speed 100/16/4 Token-Ring PCI Adapter continue with “Installing Wake on LAN Cables for the IBM High-Speed 100/16/4 Token-Ring PCI Adapter”.

Installing Wake on LAN Cables for the IBM High-Speed 100/16/4 Token-Ring PCI Adapter

For instructions on using the IBM 16/4 Token-Ring PCI Adapter 2 with Wake on LAN see “Installing Wake on LAN Cables for IBM 16/4 Token-Ring PCI Adapter 2 with Wake on LAN” on page 7.

1. Two Wake on LAN cables are included with your new adapter. Determine which to connect to your adapter in the following manner.

- If your PC has a power supply cable marked **P9** or **P12**, then you must use cable part number 42H2397. This cable has two connectors; one for the adapter and one for the system board.
 - If the cable from the power supply is not present, then you must use part number 76H7254. This cable has three connectors; two for the adapter and one for the system board.
2. Connect the cables to your adapter as follows:
- Connect the planar connector to the system board as shown in Figure 1. If you are using the two-connector cable, part number 42H2397, this connector has two pins. If you are using the three-connector cable, part number 76H7254, this connector has three pins.
 - Connect the signal connector to your adapter at **P5** as shown at number 2 in Figure 2 on page 7.
 - If you are using the three-connector cable, part number 76H7254, connect the power connector to the adapter at **P4** as shown at number 3 in Figure 2 on page 7.
- Otherwise, connect the power supply cable marked **P9** or **P12** to the adapter at **P4**. See number 3 in Figure 2 on page 7.

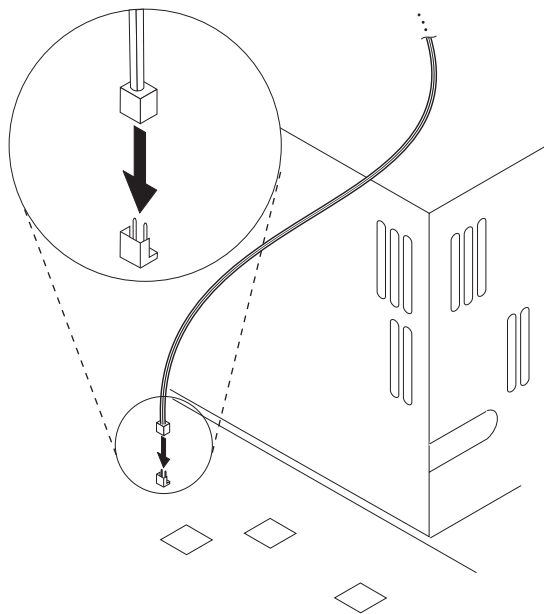

Figure 1. Wake on LAN Signal Connector on the System Board

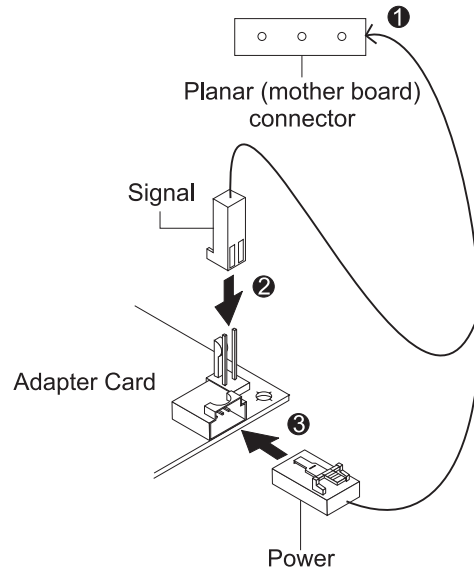

Figure 2. Connecting Cables to the adapter

3. Ensure that the adapter is secure in the PCI slot with retaining screw or other bracket lockdown mechanism.
4. Re-install all removed covers.
5. Connect the Token-Ring cable to the adapter and to the network. See “Adapter Cable” on page 8.
6. Re-connect all cables to your computer and then connect the power cord. Follow all safety instructions.

Note: In the U.K., by law, the power cord must be connected before the telephone line cable.

7. Installation is now complete. Go to “Chapter 3. Software Installation” on page 11.

Installing Wake on LAN Cables for IBM 16/4 Token-Ring PCI Adapter 2 with Wake on LAN

1. Connect the 7-pin end of the cable (P/N 30L6390) to your adapter at the opposite end from the adapter bracket.
2. Connect the other ends of the cable to the system board. These connectors go to the following system board connections:
 - Black, yellow, and red cable to the motherboard connector labeled LAN Wake.
 - Blue, white, and green cable to the motherboard connector labeled Alert.
3. Ensure that the adapter is secure in the PCI slot with retaining screw or other bracket lockdown mechanism.
4. Re-install all removed covers.
5. Connect the Token-Ring cable to the adapter and to the network. See “Adapter Cable” on page 8.
6. Re-connect all cables to your computer and then connect the power cord. Follow all safety instructions.

Note: In the U.K., by law, the power cord must be connected before the telephone line cable.

7. Installation is now complete. Go to “Chapter 3. Software Installation” on page 11.

Installing Your Adapter without the Wake on LAN Feature

1. Ensure that the adapter is secure in the PCI slot with retaining screw or other bracket lockdown mechanism.
2. Re-install all removed covers.
3. Connect the Token-Ring cable to the adapter and to the network. See “Adapter Cable”.
4. Re-connect all cables to your computer and then connect the power cord. Follow all safety instructions.

Note: In the U.K., by law, the power cord must be connected before the telephone line cable.

5. Installation is now complete. Go to “Chapter 3. Software Installation” on page 11.

Adapter Cable

To connect your adapter to a Token-Ring network, you will need one of the cables illustrated in Figure 3. Cables are not included in the package. The network end of the cable must be compatible with the network faceplate or other device to which the adapter will be connected.

Note: No more than one data cable may be connected to the adapter at a time.

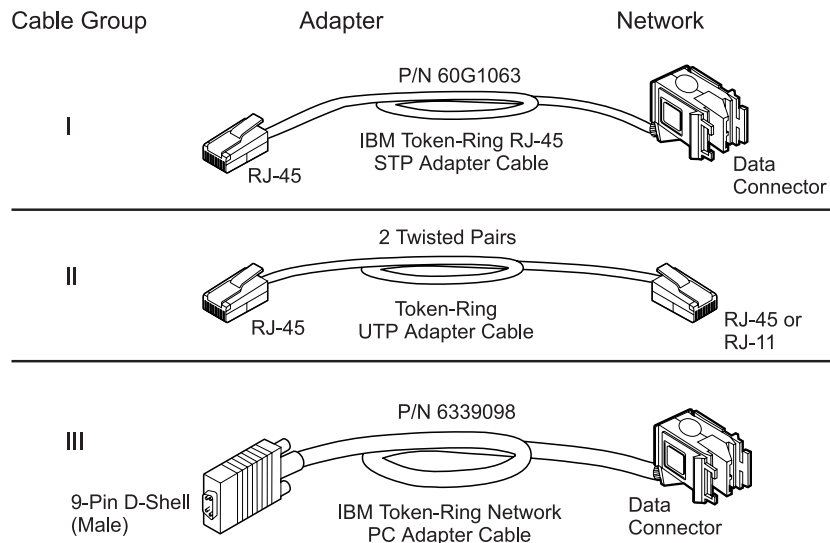

Figure 3. STP and UTP Cables

IBM 16/4 Token-Ring PCI Adapter 2 and IBM 16/4 Token-Ring PCI Adapter 2 with Wake on LAN can use any of these cables.

IBM High-Speed 100/16/4 Token-Ring PCI Adapter must use cable II (category 5 or better) or III. You cannot use cable I or the combination of P/N 60G1066 with cable III.

Chapter 3. Software Installation

1. Get the latest level of LAN driver updates for your operating system to ensure that your code is at the latest level.
2. Be sure that your IBM Token-Ring PCI Family Adapter has already been installed in your computer. If it has not, follow the instructions in "Chapter 2. Installing the Adapter Hardware" on page 5.
3. Get the driver for your environment. There are three places to find the driver. We recommend the first one listed here. All three methods will place the driver in a directory according to the structure in Table 1.
 - Method A: Get the driver from a software package on the IBM Networking Hardware Division home page on the Web. This will ensure that you get the latest driver. Go to `x:\web\lessmain.htm` (where `x` is your CD-ROM drive). Select your adapter from the section IBM Networking Web site - current information. Select **Downloads** and choose the appropriate software package for your environment. Execute the package to expand the files. The driver will be in the directory listed in Table 1.

Note: You can also access the Web site directly at www.ibm.com/networking/support

 - Method B: Use the driver shipped on this CD-ROM directly with your network operating system's installation software. Note the directory containing the driver (see Table 1).
 - Method C: Get the driver from a software package shipped on this CD-ROM. Point your Web browser to `x:\web\lessmain.htm` (where `x` is your CD-ROM drive). Select your adapter from the section CD-ROM - release date information. Select **Downloads** and choose the appropriate software package for your environment. Execute the package to expand the files. The driver will be in the directory listed in Table 1.
4. Install the driver. Use Table 2 on page 12 to find the location of the installation instructions for your environment. It is recommended that you install the latest service pack for your operating environment before installing the adapter software.

Table 1. Driver File Directory Structure

Operating System	Directory
Windows 9x	\ (root)
Windows NT	\ (root)
Novell NetWare Server and Client	\NOVELL\NETWARE
Novell NetWare DOS Requester (16-bit)	\NOVELL\DOS
Novell NetWare OS/2 Requester (16-bit)	\NOVELL\OS2
OS/2	\ (root)
DOS	\DOS
Windows for Workgroups	\WFW

Table 2. Installation Instructions

Environment	Page
DOS with Windows Version 3.1x	
IBM LAN Client	See <i>IBM Token-Ring Adapter Features</i> publication
NetWare Requester	25
DOS LAN Services	25
IBM TCP/IP for DOS (Version 2.1)	25
Windows for Workgroups with NDIS	36
DOS (without Windows)	
IBM LAN Client	See <i>IBM Token-Ring Adapter Features</i> publication
NetWare Requester	25
DOS LAN Services	25
IBM TCP/IP for DOS (Version 2.1)	25
NetWare Requester	25
NDIS2	25
IBM LAN Client	See <i>IBM Token-Ring Adapter Features</i> publication
OS/2	
OS/2 (MPTS)	22
NetWare Requester	24
OS/2 Warp Connect or Server	23
NetWare Server	
NetWare Server Version 3.12	12
NetWare Server Version 4.11	16
NetWare Server Version 5.0	19
Novell Client	21
Windows 32-bit	
NT 3.51	26
NT 4.0	27
Windows 95	28
Windows 98	32
Remote Unattended Installation (Windows NT, Windows 95, Windows 98)	34
Novell IntranetWare Client for Windows NT	35
Novell Client for Windows 95	35

Novell NetWare 3.12 Server

Before you start this installation, get the latest level of LAN driver updates for NetWare 3.12 from Novell's support Web site at support.novell.com. You will install them during the following procedure.

If the Novell NetWare server is not installed on your machine, use the following instructions. If it is installed, go to the instructions in "Server Driver Installation in Existing NetWare 3.12 Server" on page 14.

Server Driver Installation in New NetWare 3.12 Server

Changes from the usual NetWare installation are necessary because this driver is written to a new specification level that requires new NetWare loadable modules (NLMs). The installation program is not aware of this, though, and these NLMs must be loaded during installation of the server device driver and after the server installation.

1. Create a diskette containing the extracted files from the NETWAREP.EXE package file on the IBM Token-Ring PCI Family Adapter CD-ROM.
2. Refer to Novell's *Installation and Upgrade* manual for installation instructions. Follow the procedure for the installation of Novell NetWare 3.12 until the section titled "Load LAN Drivers" is next.
3. Insert the diskette that you created in step 1 into drive A. Enter the following commands at the server prompt:

```
LOAD A:\NOVELL\NETWARE\NBI31X.NLM
LOAD A:\NOVELL\NETWARE\MSM31X.NLM
LOAD A:\NOVELL\NETWARE\TOKENTSM.NLM
```

Note: A message referring to *protected-mode BIOS access* might appear before installation of Novell patches. It is for information only, and can be ignored.

4. Load the server device driver. Enter the following command at the server prompt:

```
LOAD X:\NOVELL\NETWARE\IBMTRPO.LAN DATARATE=M16
```

It is recommended for servers that the DataRate be set to M16 or M4, and clients be set to Auto. If your network is operating at 100 Mbps, this parameter is ignored. The default is Auto.

Note: See Appendix E. Novell NetWare Server and LAN Client Driver Parameters for a complete list of parameters that can be specified in the LOAD IBMTRPO command in the AUTOEXEC.NCF file.

5. Follow the instructions in the Novell manual, beginning with "Bind the Protocol to the LAN Driver" and continue until you are in the File Server STARTUP.NCF File panel.
6. In addition to the instructions in the Novell manual, add the following line to STARTUP.NCF:

```
Set Minimum Packet Receive Buffers = 48
```

Note: Increase the minimum packet receive buffers by 48 for each additional adapter that is installed.

7. Perform the instructions in "Create an AUTOEXEC.NCF file" in the Novell manual. Add the following lines to the AUTOEXEC.NCF file immediately after the IPX INTERNAL NET statement (replace C:\SERVER.312\ with the location of the NetWare server program):

```
LOAD C:\SERVER.312\NBI31X.NLM
LOAD C:\SERVER.312\MSM31X.NLM
LOAD C:\SERVER.312\TOKENTSM.NLM
LOAD C:\SERVER.312\IBMTRPO.LAN NAME=IBMLS1 DATARATE=M16
BIND IPX TO IBMLS1 NET=<unique net number>
```

Make sure that the line containing IBMTRPO.LAN has the complete path name.

Notes:

- a. See Appendix E. Novell NetWare Server and LAN Client Driver Parameters for a complete list of parameters that you can specify on the LOAD IBMTRPO command in the AUTOEXEC.NCF file.
- b. If you experience any problems after loading the Novell NLM files, contact Novell to ensure that you have the current version of these files.

Press **Esc** and answer **Yes** to save the new file to disk. Press **Esc** again to return to the server console.

8. Shut down your server by entering **down** and then entering **exit** from the server prompt.
9. Make sure that the diskette you created in step 1 is inserted in drive A. Enter the following commands at the server prompt. You might be prompted to perform a file overwrite; it is OK to overwrite these files.

```
COPY A:\NOVELL\NETWARE\NBI31X.NLM C:\SERVER.312
COPY A:\NOVELL\NETWARE\MSM31X.NLM C:\SERVER.312
COPY A:\NOVELL\NETWARE\TOKENTSM.NLM C:\SERVER.312
COPY A:\NOVELL\NETWARE\IBMTRPO.LAN C:\SERVER.312
COPY A:\NOVELL\NETWARE\IBMTRPO.LDI C:\SERVER.312
```

10. Go to the Novell server directory and enter **server** at the DOS prompt to restart the server.
11. Install the patches obtained earlier now. Make sure to select the v3.31 ODI LAN Updates for Hardware if given the opportunity.
12. Installation is now complete.

Check for the following conditions to determine whether the adapter is working correctly and whether installation has been completed successfully:

- The device driver files are loading successfully. There are no error messages.
- The adapter LEDs indicate normal operation: green ON, amber OFF. See "Understanding the Adapter LEDs and Labels" on page 39.

If you experience problems, go to Chapter 4. Problem Solving.

For information concerning NetWare server error messages, see Appendix F. Novell NetWare Server and LAN Client Driver Messages.

Server Driver Installation in Existing NetWare 3.12 Server

If Novell NetWare is already installed in your computer, perform the following steps to install the adapter server device driver.

1. Create a diskette containing the extracted files from the NETWAREP.EXE file on the IBM Token-Ring PCI Family Adapter CD-ROM.
2. Install the patches obtained earlier now. Make sure to select the v3.31 ODI LAN Updates for Hardware if given the opportunity. Return to the server console when the installation is complete.
3. Make sure that the diskette you created in step 1 is inserted in drive A. Enter the following commands at the server prompt. You might be prompted to perform a file overwrite; it is OK to overwrite these files.

```
COPY A:\NOVELL\NETWARE\NBI31X.NLM C:\SERVER.312
COPY A:\NOVELL\NETWARE\MSM31X.NLM C:\SERVER.312
COPY A:\NOVELL\NETWARE\TOKENSM.NLM C:\SERVER.312
COPY A:\NOVELL\NETWARE\IBMTRPO.LAN C:\SERVER.312
COPY A:\NOVELL\NETWARE\IBMTRPO.LDI C:\SERVER.312
```

Note: If you experience any problems after loading the Novell NLM files, check the Novell Web site to ensure that you have the current version of these files.

4. In the directory where Novell is installed on your hard disk, enter **server** at the DOS prompt to start the server.
5. At the server console prompt, enter **load install**.
6. From the Installation Options menu, select **System Options** and press **Enter**.
7. Select **Edit STARTUP.NCF File** and press **Enter**. Add the following line to the STARTUP.NCF file:

```
Set Minimum Packet Receive Buffers = 48
```

Note: Increase the minimum packet receive buffers by 48 for each additional adapter that is installed.

8. Press **Esc** and then answer **Yes** to save changes to the STARTUP.NCF file.
9. Select **Edit AUTOEXEC.NCF File** and press **Enter**. Edit this file and, after the IPX internal net statement, include the following statements. (Replace C:\SERVER.312\ with the location of the NetWare server program.)

It is recommended for servers that the DataRate be set to M16 or M4, and clients be set to Auto. If your system is 100 MB, this parameter is ignored. The default is Auto.

```
LOAD C:\SERVER.312\NBI31X
LOAD C:\SERVER.312\MSM31X
LOAD C:\SERVER.312\TOKENSM
LOAD C:\SERVER.312\IBMTRPO NAME=IBMLS1 DATARATE=M16
BIND IPX TO IBMLS1 NET=<unique net number>
```

See Appendix E. Novell NetWare Server and LAN Client Driver Parameters for a complete list of parameters that can be specified on the LOAD IBMTRPO command in the AUTOEXEC.NCF file.

Press **Esc** and then answer **Yes** to save the new file to disk. Press **Esc** again to return to the server console.

10. Shut down your server by entering **down** and then entering **exit** from the server prompt.
11. Enter **server** to restart the server.
12. Installation is now complete. Shut down and restart your computer for all changes to take effect.

Check for the following conditions to determine whether the adapter is working correctly and whether installation has been completed successfully:

- The device driver files are loading successfully. There are no error messages.
- The adapter LEDs indicate normal operation: green ON, amber OFF. See “Understanding the Adapter LEDs and Labels” on page 39.

If you experience problems, go to Chapter 4. Problem Solving.

For information concerning NetWare server error messages, see Appendix F. Novell NetWare Server and LAN Client Driver Messages.

Novell NetWare 4.11 Server

Before you start this installation, get the latest level of patches from Novell's support Web site at <http://support.novell.com> and install them.

If Novell NetWare is not installed on your machine, use the following instructions. If it is installed, follow the instructions in "Server Driver Installation in Existing NetWare 4.11 Server" on page 17.

Server Driver Installation in New NetWare 4.11 Server

Changes from the usual NetWare installation are necessary because this driver is written to a new specification level that requires new NetWare loadable modules (NLMs). The installation program is not aware of this, though, and these NLMs must be loaded during installation of the server device driver and after the server installation.

Note: A message referring to protected-mode BIOS access might appear before installation of Novell patches. It is for information only, and can be ignored.

1. Create a diskette containing the extracted files from the NETWAREP.EXE package file on the IBM Token-Ring PCI Family Adapter CD-ROM.
2. When you see `INSTALL Found the following : PCI LAN Controller xxxx.xxxx.xxxx` press **Enter**. Then press the Insert (**INS**) key to install the unlisted driver.
3. Press **ALT-ESC** to toggle to the server console, and enter the following LOAD statements (make sure that the diskette that you created in step 1 is inserted in drive A):

```
LOAD A:\NOVELL\NETWARE\MSM.NLM
LOAD A:\NOVELL\NETWARE\TOKENSM.NLM
```

4. Press **ALT-ESC** to toggle back to the INSTALL panel.
5. Press **F3** on the next panel to specify `A:\NOVELL\NETWARE` as the directory path.

Press **Enter** then follow the instructions on the panel to complete the installation of the driver. If you need to make any custom configuration changes to the driver, do so at this time.

6. Follow the instructions in the Novell manual *Create an AUTOEXEC.NCF file*. In addition to the instructions in the manual, add the following lines to the AUTOEXEC.NCF file immediately after the IPX INTERNAL NET statement (if necessary, replace `C:\NWSERVER` with the location of the SERVER.EXE executable):

```
LOAD C:\NWSERVER\NBI.NLM
LOAD C:\NWSERVER\MSM.NLM
LOAD C:\NWSERVER\TOKENSM.NLM
LOAD C:\NWSERVER\IBMTRPO.LAN NAME=IBMLS1 DATARATE=M16
```

Note: There will be existing LOAD and BIND IPX statements in the AUTOEXEC.NCF. Delete the LOAD statement (we have replaced it with stated `LOAD C:\NWSERVER\IBMTRPO.LAN` statement). Also, make any needed modifications to the existing BIND IPX statement (refer to the *Bind the Protocol to the LAN Driver* section of the Novell manual for additional information).

See “Appendix E. Novell NetWare Server and LAN Client Driver Parameters” on page 63 for a complete list of parameters that can be specified on the LOAD IBMTRPO command in the AUTOEXEC.NCF file.

7. Press **ESC** and answer **YES** to save the new file to disk. Press **ESC** again to return to the server console.
8. Type the following commands from the server prompt to shut down the server and exit to DOS: **down**, then **exit**.
9. Perform the following COPY commands, making sure that the diskette that you created in step 1 is inserted in drive A. Note that it will prompt you at each of the following files to ask if you want to perform a file overwrite; it is OK to overwrite these files.

```
COPY A:\NOVELL\NETWARE\NBI.NLM C:\NWSERVER
COPY A:\NOVELL\NETWARE\MSM.NLM C:\NWSERVER
COPY A:\NOVELL\NETWARE\TOKENSM.NLM C:\NWSERVER
COPY A:\NOVELL\NETWARE\IBMTRPO.LAN C:\NWSERVER
COPY A:\NOVELL\NETWARE\IBMTRPO.LDI C:\NWSERVER
```

10. Go to the Novell server directory and enter **server** at the DOS prompt to restart the server.
11. Install the latest available Novell patches for NetWare 4.11 now. Make sure to select the Version 3.31 ODI LAN Updates for Hardware if given the opportunity.
12. Issue the following commands from the server prompt to bring the server down, then reboot it: **down**, then **restart server**.
13. Installation is now complete. Check for the following conditions to determine whether the adapter is working correctly and whether installation has been completed successfully:
 - The device driver files are loading successfully. There are no error messages.
 - The adapter LEDs indicate normal operation. green ON, amber OFF. See “Understanding the Adapter LEDs and Labels” on page 39.

If you experience problems, go to Chapter 4. Problem Solving.

For information concerning NetWare server error messages, see Appendix F. Novell NetWare Server and LAN Client Driver Messages.

Server Driver Installation in Existing NetWare 4.11 Server

If Novell NetWare is already installed in your computer, perform the following steps to install the adapter server device driver.

Note: If you are altering the configuration of a previously loaded adapter, unload that adapter before proceeding with these instructions.

1. Create a diskette containing the extracted files from the NETWAREP.EXE file on the IBM Token-Ring PCI Family Adapter CD-ROM.
2. Be sure that your IBM Token-Ring PCI Family Adapter has already been installed in your computer. If it has not, follow the instructions in “Chapter 2. Installing the Adapter Hardware” on page 5.

3. Install the latest available Novell patches for NetWare 4.11. Make sure to select the Version 3.31 ODI LAN Updates for Hardware if given the opportunity. Return to the server console when the installation is complete.
4. Issue the following commands from the server prompt to bring the server down, then restart it again:

```

down
restart server

```

5. Check to see if the device driver is loaded. If it is, unload it using the following command: **unload ibmtrpo**
6. Type **load install** on the server.
7. Select **Driver Options**.
8. Select **Configure Network Drivers**.
9. Select **Select Drivers**.
10. On the next panel, press the Insert (**INS**) key to install the unlisted driver.
11. Insert the diskette that you created in step 1; press **F3** on the next panel and specify the path A:\NOVELL\NETWARE.
12. Follow the instructions on the panels to complete the installation of the driver. If you need to make any custom configuration changes to the driver, do so at this time.
13. Follow the instructions in the Novell manual *Create an AUTOEXEC.NCF file*. In addition to the instructions in the manual, add the following lines to the AUTOEXEC.NCF file, immediately after the IPX INTERNAL NET statement (if necessary, replace C:\NWSERVER with the actual location of the SERVER.EXE executable):

```

LOAD C:\NWSERVER\NBI.NLM
LOAD C:\NWSERVER\MSM.NLM
LOAD C:\NWSERVER\TKENTSM.NLM
LOAD C:\NWSERVER\IBMTRPO.LAN NAME=IBMLS1 DATARATE=M16

```

Note: There will be existing LOAD and BIND IPX statements in the AUTOEXEC.NCF. Delete the LOAD statement (we have replaced it with the stated LOAD C:\NWSERVER\IBMTRPO.LAN statement).

Also, make any needed modifications to the existing BIND IPX statement (refer to the *Bind the Protocol to the LAN Driver* section of the Novell manual for additional information).

See Appendix E. Novell NetWare Server and LAN Client Driver Parameters for a complete list of parameters that can be specified on the LOAD IBMTRPO command in the AUTOEXEC.NCF file.

14. Press **ESC** and answer **YES** to save the new file to disk. Press **ESC** again to return to the server console.
15. Type the following commands from the server prompt to shut down the server and exit to DOS: **down**, and then **exit**.
16. Perform the following COPY commands, making sure that the diskette that you created in step 1 is inserted in drive A. Note that it will prompt you at each of the following files to ask if you want to perform a file overwrite; it is OK to overwrite these files.

```
COPY A:\NOVELL\NETWARE\NBI.NLM C:\NWSERVER
COPY A:\NOVELL\NETWARE\MSM.NLM C:\NWSERVER
COPY A:\NOVELL\NETWARE\TOKENSM.NLM C:\NWSERVER
COPY A:\NOVELL\NETWARE\IBMTRPO.LAN C:\NWSERVER
COPY A:\NOVELL\NETWARE\IBMTRPO.LDI C:\NWSERVER
```

17. Go to the Novell server directory and enter **server** at the DOS prompt to restart the server.
18. Installation is now complete. Check for the following conditions to determine whether the adapter is working correctly and whether installation has been completed successfully:
 - The device driver files are loading successfully. There are no error messages.
 - The adapter LEDs indicate normal operation. green ON, amber OFF. See “Understanding the Adapter LEDs and Labels” on page 39.

If you experience problems, go to Chapter 4. Problem Solving.

For information concerning NetWare server error messages, see Appendix F. Novell NetWare Server and LAN Client Driver Messages.

Novell NetWare 5.0 Server

Server Driver Installation During NetWare 5.0 Server Installation

Installation of the network board and its device driver occurs during the combined storage device and network board installation step. Use the following instructions to install the network board and its driver during a new NetWare 5.0 server installation.

1. Create a device driver installation diskette.
Create a diskette containing the extracted files from the NETWAREP.EXE package file on the IBM Token-Ring PCI Family Adapter CD-ROM.
2. Select a Storage Device and a Network Board.
To select a storage device and a network board, you must:
 - Select and configure the storage device
 - Select and configure the network board
 - Load a NetWare Loadable Module TM program (if required)

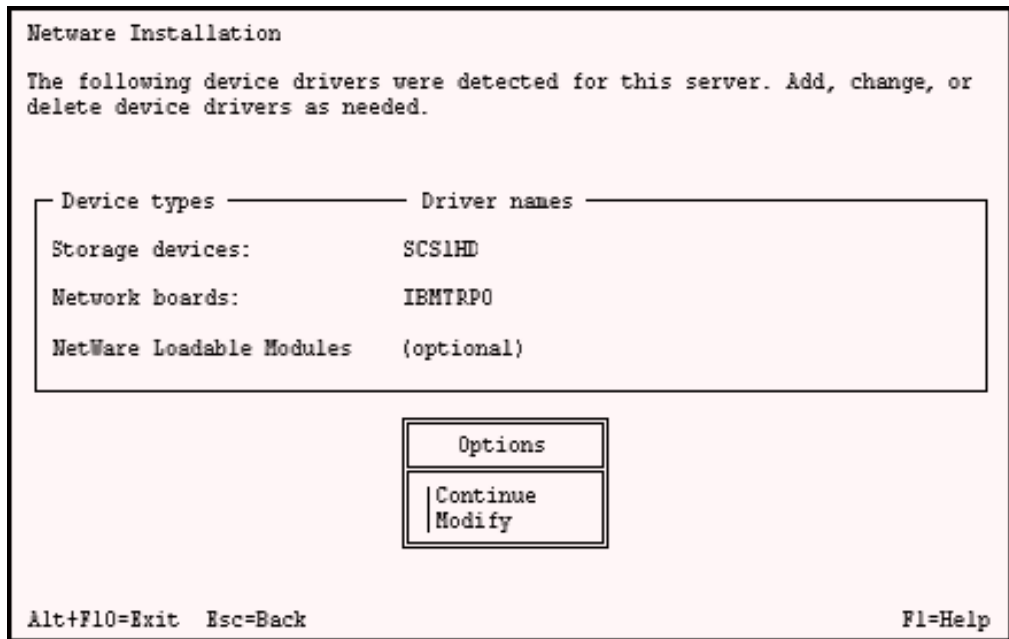

To add a driver: in the Options box, select **Modify**. Then select the driver and press **Enter**. Press **Insert** to select from a list of drivers provided with NetWare. Press **Insert** again to install a driver from diskette.

To delete a driver: in the Options box, select **Modify**. Select the driver and press **Enter**. Select the driver to delete and press **Delete**.

To modify a driver: in the Options box, select **Modify**. Select the driver and press **Enter**. Select the driver to modify and press **Enter**. Select the property to modify.

3. Select a storage device.

Storage devices such as hard disks, CD-ROMs, and tape devices require a software driver to communicate with the storage adapter. The software driver for the storage device is called a custom device module (CDM). Each type of storage device requires a CDM.

The installation program auto-detects many types of storage devices such as IDE drives, SCSI drives, CD-ROM drives, and tape drives. If your storage device is not detected, choose the appropriate driver from the list of available drivers provided with NetWare 5 or add a new driver from a diskette. CDMs can be obtained from the storage device manufacturer.

4. Select a Network Board.

The software driver for a network board is called a LAN driver.

The installation program auto-detects many types of network boards. If your network board is not detected, choose the driver for the network board from the list provided with NetWare 5 or use a new or updated driver from the diskette that you created in step 1.

The network board must be installed and configured correctly. For servers, it is recommended that DATARATE be set to M16 or M4, and clients be set to Auto. If your network is operating at 100 Mbps, this parameter is ignored. You might be able to influence certain network board properties by configuring the system and the network board or both.

5. Load a NetWare Loadable Module (if required).

Certain server and network configurations might require you to load a NetWare Loadable Module (NLM) before you can complete the server installation. An example is loading ROUTE.NLM for a Token-Ring environment that requires it.

Server Driver Installation in Existing NetWare 5.0 Server

The following procedure explains how to use NWCONFIG to load a LAN driver and bind a protocol.

1. Create a diskette containing the extracted files from the NETWAREP.EXE package file on the IBM Token-Ring PCI Family Adapter CD-ROM.
2. At the server console prompt, enter NWCONFIG.
3. Select **Driver Options**► **Configure network drivers**►.
4. To select a driver from all of the available drivers, choose **Select a driver**. The screen will display a list of all available drivers.
5. Press **Insert**. Follow the instructions on the panels. Use the diskette that you created in step 1 when you are prompted to supply an unlisted driver. The directory is A:\NOVELL\NETWARE.

Note: For some drivers, a message might appear indicating that the driver must be loaded manually (at the console prompt). To load a driver manually, follow the screen prompts or press **F1** for more information.

6. Set protocols. When the window containing protocol choices is displayed, select the protocol that you want to use and press the space bar. If you select TCP/IP, enter the IP address and the IP mask.
7. Set parameters. Use the down arrow key to move the cursor to the parameter window. Enter parameter values as needed. Press **F1** for help. It is recommended for servers that the Data Rate be set to 4 Mbps or 16 Mbps, and clients be set to Automatic. If your server is operating at 100 Mbps, set this parameter to Automatic.

In some cases, the system displays a pop-up list of values for the field from which you select the desired value. In other cases, you must type in a value and press **Enter** to move to the next field.
8. To specify a particular frame type for a Token-Ring driver, press **F3** to display a list of frame types. Use the arrow keys to move up and down the list. Press **Enter** to select a frame type. When finished, press **F10**. If you do not specify a particular frame type, all frame types are loaded automatically, but only those found on the network are actually bound to the driver.
9. Select **Save parameters and load driver**.
10. Confirm bindings of the protocol with the driver and the network number.
11. Driver installation is now complete. To add another adapter, down the server, power off the server, and insert the additional driver. NetWare will load the appropriate driver automatically. Then repeat step 10.

Novell Client DOS/Windows 3.1x

1. Download Novell Client DOS/Windows 3.1x Version 2.5 or higher from Novell's Web site (<http://support.novell.com>). Unzip the downloaded file to a directory on your computer.
2. Exit Windows.
3. From a DOS prompt, go to the directory where you put the file. Run INSTALL.EXE.
4. Select **Yes** or **No** to respond to the Novell License Agreement.

5. Select **Novell Client Windows Support** and **Work Station Manager 3.X**. Press **F10** to save and continue.
6. Select **32-bit LAN Drivers** and press **F10** to save and continue.
7. Select **USER SPECIFIED 32-Bit Driver** and press **Enter**. Insert the CD-ROM or the diskette containing the device drivers into the appropriate drive. Enter the path to the 32-bit ODI driver: **x:\novell\netware** where x is your CD-ROM drive letter. The panel should say
IBM Token-Ring PCI Family Adapter

Press **Enter**, configure the parameters, and press **F10** to save and continue.
8. At the panel entitled Installation Configuration Summary, confirm that the values are what you selected, and press **F10** to save and continue.
9. The files will be copied at this point.
10. Installation is now complete.
11. Reboot your computer and start Windows to connect to and login to your server.
12. Check for the following conditions to determine whether the adapter is working correctly and whether installation has been completed successfully:
 - The device driver files are loading successfully. There are no error messages.
 - The adapter LEDs indicate normal operation. green ON, amber OFF. See "Understanding the Adapter LEDs and Labels" on page 39.

If you experience problems, go to Chapter 4. Problem Solving.

OS/2 NDIS 2 Device Driver Using MPTS

MPTS is the Multiple Protocol Transport Services.

1. When updating an existing device driver, error message X100035, which indicates that the driver could not be installed and the previous version could not be restored, can be prevented by performing the following steps before beginning the update. This is particularly useful when the existing driver was installed from the adapter CD-ROM.
 - From an OS/2 window, go to the drive where OS/2 is installed. Change to the IBMCOM subdirectory (where x is your drive letter):

```
x:  
cd \ibmcom
```
 - Enter the following two commands:

```
attrib -r ibmtrp.* /s  
attrib -r la1*.msg
```
2. Start MPTS by performing either of the following actions:
 - From the OS/2 desktop, double-click the MPTS icon.
 - From an OS/2 window, go into the IBMCOM subdirectory and enter **mpts** at the OS/2 prompt.
3. Select **OK** on the MPTS logo panel.
4. Select **Install**. You will be prompted for the source of the .NIF file. Enter the path to the driver directory. Select **OK** once the Installation Complete message appears. You will return to the main menu.

5. Select **Configure** in the MPTS dialog box.
6. On the Configure panel, make sure that **LAN adapters and protocols** is preselected and then select **Configure** at the bottom of the panel.
7. In the Configuration panel, in the Network Adapters group box, select **IBM Token-Ring PCI Family Adapter (IBMTRP.OS2)** and select **ADD**.

Note: You can edit parameter settings for this adapter. Highlight your adapter in the Current Configuration list box and select **Edit**.

8. In the Protocols list box, select the protocols used by your network application. Highlight each protocol and select **ADD**. If you are not sure which ones to use, select **IBM IEEE 802.2** and **IBM OS/2 NetBIOS** protocol drivers or ask your network administrator.

The protocol drivers you have selected will appear under the adapter driver name in the Current Configuration list box.

Note: You can edit parameter settings for the protocols. Highlight a protocol and select **Edit**.

9. Select **OK** when you have finished selecting and editing protocols in the MPTS Configuration panel.
10. Select **Close** on the Configure panel.
11. Select **Exit** in the MPTS dialog box.
12. Select **Exit** on the Update CONFIG.SYS panel to update the CONFIG.SYS file.
13. Select **OK** when you get the message that the CONFIG.SYS has been successfully updated.
14. Select **Exit** on the Exiting MPTS panel.
15. Shut down and restart your computer to let the changes take effect. Installation is now complete.
16. At system startup, check for the following conditions to determine whether the adapter is working correctly and whether installation has been completed successfully:
 - The device driver files loaded successfully. There are no error messages.
 - The adapter LEDs indicate normal operation: green ON, amber OFF.

If you experience problems, go to Chapter 4. Problem Solving.

For information concerning NDIS driver error messages, see Appendix D. NDIS 2 Device Driver Messages.

OS/2 NDIS 2 Device Driver Using Other Installation Programs

1. Insert the CD-ROM or the NDIS Drivers diskette into the appropriate drive.
2. Use your product documentation to install the driver (IBMTRP.OS2), which is located in the root directory on both the CD-ROM and diskette.
3. Modify the parameters if needed. See Appendix C. NDIS 2 Device Driver Parameters.

IBM TCP/IP for OS/2 and Warp Connect are examples of products that provide driver installation programs.

4. Installation is now complete. Shut down and restart your computer for all changes to take effect.

5. Check for the following conditions to determine whether the adapter is working correctly and whether installation has been completed successfully:
 - The device driver files load successfully. There are no error messages.
 - The adapter LEDs indicate normal operation: green ON, amber OFF.

If you experience problems, go to Chapter 4. Problem Solving.

For information concerning NDIS driver error messages, see Appendix D. NDIS 2 Device Driver Messages.

OS/2 Novell NetWare Requester

Before installation, copy IBMTRPO.SYS from the CD-ROM or the ODI Drivers and LAN Client (A) diskette to the root directory containing your Novell NetWare Requester source files.

1. Refer to the workstation basics and installation manuals from Novell to begin. When a dialog box titled Requester Installation appears during the installation process, continue with the following steps.
2. If you are installing the NetWare Requester on a workstation, select **Edit CONFIG.SYS and Copy All Files....** If the NetWare Requester is already installed on the workstation and only a driver update is needed, then select **Only Edit CONFIG.SYS....**
3. On the next panel, specify the name of the adapter driver: IBMTRPO.SYS.
4. When you get to the panel labeled "Copy ODI LAN Driver files," select **Copy only the default driver.**
5. Continue with the installation, following the instructions on the panels.
6. When Installation Complete appears in the Requester window, go to the Configuration menu and select **This workstation....**
7. Select **Edit** to accept the default location for the NET.CFG file.
8. In the edit box titled Current NET.CFG File Contents, type the following lines:

```
link driver IBMTRPO
  SLOT 10001
link support
  BUFFERS 8 4096
```

Notes:

- a. See Appendix G. Novell NetWare DOS ODI Driver Parameters for a complete list of parameters that you can specify in the NET.CFG file.
 - b. To enable source routing, changes will have to be made to the CONFIG.SYS file. Refer to Novell's *Workstation for OS/2* manual for instructions on how to enable source routing.
 - c. The lines in the NetWare Requester section of the CONFIG.SYS file must be in a certain order. Do not reorder the lines in this section of CONFIG.SYS. Refer to the Novell manuals for more information.
9. Select **Save** to complete the NetWare Requester installation.
 10. Reboot the computer for the changes to take effect.

Note: To make changes in the NetWare Requester configuration, double-click the Novell icon on the desktop. Double-click the Install icon in the Novell window. Go to the Configuration and select **This workstation....** Make sure that the correct NET.CFG is shown in the next dialog box and select **Edit**. Edit the NET.CFG file in the edit box titled Current

NET.CFG File Contents. When the changes are complete, select **Save**. It is necessary to reboot the computer in order to make the changes take effect.

11. Installation is now complete. Check for the following conditions to determine whether the adapter is working correctly and whether installation has been completed successfully:
 - The device driver files loaded successfully. There are no error messages.
 - The adapter LEDs indicate normal operation: green ON, amber OFF.

If you experience problems, go to Chapter 4. Problem Solving.

DOS NDIS 2

Note: It is recommended that you use LAN Client (Client32) whenever possible as an efficient solution.

1. Insert the CD-ROM or the NDIS Drivers diskette into the appropriate drive.
2. Use your operating system documentation to install the driver (IBMTRP.DOS). This driver is located in the \dos subdirectory on both diskette and the CD-ROM.
3. Modify the parameters, if needed. See Appendix C. NDIS 2 Device Driver Parameters.

Note: If you use Microsoft™ Windows™ for Workgroups and want to configure the NetAddress parameter for the NDIS device driver, remember to enclose the address in double quotes (" "). The NetAddress parameter is used to set a locally administered address for the adapter.

4. Installation is now complete. Shut down and restart your computer for all changes to take effect.
5. Check for the following conditions to determine whether the adapter is working correctly and whether installation has been completed successfully:
 - The device driver files load successfully. There are no error messages. If error messages are displayed or if you do not see messages that indicate that the drivers have been installed, go to "Start of Troubleshooting Process" on page 37.
 - The adapter LEDs indicate normal operation: green ON, amber OFF.

If you experience problems, go to Chapter 4. Problem Solving.

For information concerning NDIS driver error messages, see Appendix D. NDIS 2 Device Driver Messages.

DOS Novell NetWare Requester (16-bit)

Note: It is recommended that you use LAN Client (Client32) whenever possible as an efficient solution.

The 16-bit DOS Novell NetWare Requester environment supports access to servers running Novell NetWare 3.11 or higher.

To install the IBMTRPO.EXE ODI driver on a DOS computer, perform the following steps:

Note: Consult your Novell NetWare documentation for instructions regarding how to create the NetWare Client for DOS and MS Windows diskettes.

1. Create a diskette containing the extracted files from the DOSODIP.EXE file on the IBM Token-Ring PCI Family Adapter CD-ROM.
2. Insert the NetWare Client for DOS and MS Windows Disk 1 into the appropriate drive.
3. At the command prompt, type **X:**, where X is your drive letter, and then press **Enter**.
4. Type **install** and then press **Enter**.
5. Follow the instructions as they appear. In step 5, select the driver for your network board. Scroll down through Network Boards, highlight **Other Drivers**; then press **Enter**.
6. Insert the CD-ROM or the diskette that you created in step 1 into the appropriate drive. When prompted, specify the location to the chosen media and press **Enter**. Specify the path as A:\NOVELL\DOS (or at X:\NOVELL\DOS for the CD-ROM version).
7. Highlight your adapter and press **Enter**.
8. At this time you can change the default parameters. When you finish making any desired changes, press **F10**. Appendix G, Novell NetWare DOS ODI Driver Parameters contains the parameters that can be configured in the NET.CFG file.
9. Follow the instructions presented to finish the installation.

Note: If source routing is required, edit the STARTNET.BAT file that is in the client directory (usually C:\NWCLIENT) and add the following line after the IPXODI statement:

```
C:\NWCLIENT\ROUTE
```

10. Shut down and restart your computer for all changes to take effect.
11. Check for the following conditions to determine whether the adapter is working correctly and whether installation has been completed successfully:
 - The device driver files load successfully. There are no error messages. If error messages are displayed or if you do not see messages that indicate that the drivers have been installed, go to "Start of Troubleshooting Process" on page 37.
 - The adapter LEDs indicate normal operation: green ON, amber OFF.

If you experience problems, go to Chapter 4, Problem Solving.

Windows NT™ Version 3.51

The following procedure assumes that Windows NT 3.51 has already been installed with networking support. It is highly recommended that you install Service Pack 5 from Microsoft before installing the driver.

1. Log on to Windows NT as an administrator.
2. From the **Main** program group within the Program Manager, find and double-click the **Control Panel** icon.
3. In the Control Panel window, double-click the **Network** icon.

4. In the Network Setting, select **Add Adapter**.
5. In the Add Network Adapter dialog box, click the drop-down list for Network Adapter Card. Scroll down the list and select **<Other> Requires disk from manufacturer**. Then, select **Continue**.
6. Insert the CD-ROM or the diskette containing the device drivers into the appropriate drive. When prompted, enter the path to the driver directory and select **OK**.
7. Select **OK** to accept the drive and path information.
8. In the Select OEM Option dialog box, select **IBM Token-Ring PCI Family Adapter**.

Several work-in-progress panels are displayed, indicating that the driver and its supporting files are being copied to your computer's hard disk.

9. The Network Control panel is displayed again. There should be an entry in the Installed Adapter Cards list for each IBM Token-Ring PCI Family Adapter found in the computer.

To change default values for an adapter, select that adapter in the Installed Adapters list box, and then select **Configure**. Make the necessary changes and select **OK**.

Note: Make sure that all of the appropriate protocols are installed to connect to the network. Consult your network administrator if you are unsure of what protocols need to be installed.

10. Select **OK** at the top right to complete the installation.

Note: If TCP/IP is installed as a protocol on the computer, you will now see the TCP/IP configuration panel. Enter all necessary information and select **OK**.

11. The following message will be displayed:

Your network settings have changed.
You will need to exit and restart Windows NT so that the new settings can take effect.

Select **Restart now** in order to have Windows NT automatically restart your computer.

12. Installation is now complete. You might need to reinstall Service Pack 5 due to changes to your services or protocols during installation.
13. Check for the following conditions to determine whether the adapter is working correctly and whether installation has been completed successfully:
 - The device driver files loaded successfully.
 - There are no error messages logged for the IBMTRP service in the Event Viewer.
 - The adapter LEDs indicate normal operation: green ON, amber OFF.

If you experience problems, go to Chapter 4. Problem Solving.

Windows NT Version 4.0

The following procedure assumes that Windows NT 4.0 has already been installed with networking support. It is highly recommended that you install Service Pack 3 or higher from Microsoft before installing the driver.

1. Log on to Windows NT as an administrator.

2. Select **Start ► Settings ► Control Panel**.
3. From the Control Panel window, double-click the **Network** icon.
4. Select the **Adapters** tab.
5. Select **Add**.
6. You will see a dialog box that includes a list of adapters. Select **Have Disk...**
7. Insert the CD-ROM or the diskette containing the device drivers into the appropriate drive. When prompted, enter the path to the root directory of the CD-ROM or diskette and select **OK**.
8. In the Select OEM Option dialog box, select **IBM Token-Ring PCI Family Adapter** and then select **OK**.
Several work-in-progress panels are displayed, indicating that the driver and its supporting files are being copied to your computer's hard disk.
9. The Network Control panel is displayed again. There should be an entry in the Installed Adapters list for each IBM Token-Ring PCI Family Adapter found in the computer.
To change default values for an adapter, select that adapter on the Network Adapters list, and then select **Properties**. Make the necessary changes and select **OK**.

Note: Make sure that all of the appropriate protocols are installed to connect to the network. Consult your network administrator if you are unsure of what protocols need to be installed.

10. Select **Close** to complete the installation.

Note: If TCP/IP is installed as a protocol on the computer, you will now see the TCP/IP configuration panel. Enter all necessary information and select **OK**.

11. The following message will be displayed:
Your network settings have changed.
You will need to exit and restart Windows NT so that the new settings can take effect.

Select **Yes** in order to have Windows NT automatically restart your computer.

12. Installation is now complete. You might need to reinstall the Service Pack due to changes to your services or protocols during installation.
13. Check for the following conditions to determine whether the adapter is working correctly and whether installation has been completed successfully:
 - The device driver files loaded successfully.
 - There are no error messages logged for the IBMTRP service in the Event Viewer.
 - The adapter LEDs indicate normal operation: green ON, amber OFF.

If you experience problems, go to Chapter 4. Problem Solving.

Windows 95

There are two different versions of Windows 95 in distribution: the retail release, which can be purchased by individuals, and the OEM Service Release 2 (OSR2), which is found on most computer system preloads. To find out if you are running the OSR2 release, select **Start ► Settings ► Control Panel**, and then double-click the **System** icon. Look at the version number under the text Microsoft Windows 95.

- If the number is 4.00.950a or 4.00.950, you are using the retail release of Windows 95.
- If the number is 4.00.950 B, you are using the OSR2 release of Windows 95.

Make sure that you refer to the appropriate installation section for the version of Windows 95 that you are using.

Before beginning installation, shut down the computer. Make sure that the operating system is correctly shut down and then switch off the power and disconnect the power cable from the power source.

If Windows 95 Retail is Already Installed

1. When you boot Windows 95, it will detect the new hardware and bring up a dialog box to allow a choice of drivers. Select **Driver from disk provided by hardware manufacturer** and then select **OK**.
2. Insert the CD-ROM or the NDIS Drivers diskette into the appropriate drive. When prompted, enter the path to the driver directory and select **OK**.

Note: Some of the files on the diskette are located in the DOS subdirectory. If necessary, you will have to supply this subdirectory to get additional files copied onto your computer.

3. At this point, Windows 95 might prompt you for network names. Type your computer's name and workgroup. Consult your system administrator if you do not know this information. Select **OK** to continue.
4. The driver files will be copied. Windows might prompt you for the Windows 95 CD-ROM in order to install its default network protocols and services. Make sure that the location of your Windows 95 installation files (for example, D:\ or D:\WIN95 or C:\WINDOWS\CATROOT) appears in the entry and select **OK**.
5. After the files have been copied, a dialog box will display the following message:

To finish setting up your new hardware, you must restart your computer. Do you want to restart your computer now?

Remove the diskette or CD-ROM from the computer and select **Yes**.

6. Installation is now complete.

Check for the following conditions to determine whether the adapter is working correctly and whether installation has been completed successfully:

 - The device driver files loaded successfully.
 - The device manager (System control panel applet) reports that the device is working correctly.
 - The adapter LEDs indicate normal operation: green ON, amber OFF.

If you experience problems, go to Chapter 4. Problem Solving.

If Windows 95 OSR2 Is Already Installed

1. When you boot Windows 95, it will detect the new hardware and display the Update Device Driver Wizard dialog which displays the following message:

This wizard will complete the installation of: PCI Token Ring Controller.

Insert the adapter CD-ROM or the NDIS Drivers diskette containing the device drivers into the appropriate drive.

2. Insert the CD-ROM or the NDIS Drivers diskette into the appropriate drive. When prompted, enter the path to the driver directory and select **OK**.

Note: Some of the files on the diskette are located in the DOS subdirectory. If necessary, you will have to supply this subdirectory to get additional files copied onto your computer.

3. At this point, Windows 95 might prompt you for network names. Type in your computer's name and workgroup. Consult your system administrator if you do not know this information. Select **OK** to continue.
4. The driver files will be copied at this point. Windows might prompt you for the Windows 95 CD-ROM in order to install its default network protocols and services. Make sure that the location of your Windows 95 installation files (for example, D:\ or D:\WIN95 or C:\WINDOWS\CATROOT) appears in the entry and select **OK**. You might also be prompted again for the location of the driver files. Enter the appropriate location again as described previously.
5. After the files have been copied, a dialog box will display the following message:

To finish setting up your new hardware, you must restart the computer. Do you want to restart your computer now?

Remove the driver diskette or CD-ROM from the computer and select **Yes**.

6. Installation is now complete.
Check for the following conditions to determine whether the adapter is working correctly and whether installation has been completed successfully:
 - The device driver files loaded successfully.
 - The Device Manager (System control panel applet) reports that the device is working correctly.
 - The adapter LEDs indicate normal operation: green ON, amber OFF.

If you experience problems, go to Chapter 4. Problem Solving.

First-Time Installation of Windows 95 with the IBM Token-Ring PCI Family Adapter

If Windows 95 is installed on a computer with the IBM Token-Ring PCI Family Adapter already installed, Windows 95 will detect the adapter, but will not install any drivers. Use the following procedure to correct the problem.

1. Insert the NDIS Drivers diskette or the CD-ROM into the appropriate drive.
2. Select **Start ► Settings ► Control Panel**. This will display the Control Panel.
3. In the Control Panel window, double-click the **System** icon.
4. Select the **Device Manager** tab.
5. Within the Device Manager, expand the Other Devices section by selecting the **+** icon that appears to the left of the words **Other Devices**. Select the entry for **PCI Token Ring Controller** and then select **Properties**.
6. Select the **Driver** tab. Depending on which version of Windows 95 you have (retail or OSR2), this dialog will look different. If the Driver properties sheet has a Change Driver button, continue with "Continuing Installation of the Driver without the Device Wizard" on page 31. If, however, the properties sheet has an Update Driver button instead, continue with "Continuing Installation of the Driver Using the Update Device Driver Wizard" on page 31.

Continuing Installation of the Driver without the Device Wizard

1. Select the **Change Driver** button to display the Select Hardware Type dialog. Select **Network adapters** and select **OK**.
2. Select **Have Disk** from the Select Device dialog. Type the letter of your CD-ROM drive and select **OK**.

Note: Some of the files on the diskette are located in the DOS subdirectory. If necessary, you will have to supply this subdirectory to get additional files copied onto your computer.

3. Windows will display a list of compatible devices. Make sure that your adapter is selected and then select **OK**.
4. Windows will return to the PCI Token Ring Controllers Properties dialog box. Select **OK** to continue.
5. At this point, Windows might prompt you for network names. Type your computer's name and workgroup. Consult your system administrator if you do not know this information. Select **OK** to continue.
The driver files will be copied at this point. Windows might prompt you for the Windows 95 CD-ROM in order to install default network protocols and services. Make sure that the location of your Windows 95 installation files (for example, D:\ or D:\WIN95 or C:\WINDOWS\CATROOT) appears in the entry and select **OK**.
6. If Windows 95 displays a dialog that warns you that the PCI Token-Ring Controller has a ROM, ignore the message and select **Test** to continue.
7. Select **OK** in the Device Manager.
8. Remove the driver diskette or CD-ROM. Reboot your computer (select **Start ► Shut Down** and select **Restart the computer**).
9. Installation is now complete.

Continuing Installation of the Driver Using the Update Device Driver Wizard

1. Select the **Update Driver** button on the properties sheet. Windows will display the Update Device Driver Wizard dialog. The dialog box should read
This wizard will complete the installation of: PCI Token Ring Controller.

Insert the product CD-ROM or the the NDIS Drivers diskette into the appropriate drive.

2. Select **Next** to search for the drivers. Windows 95 will search the diskette or CD-ROM drives for an appropriate driver. At this point, the wizard should state that

Windows has found the following updated driver
for this device.

Select **Finish** to continue the installation.

Note: If the search fails, select **Other Locations**. Type the letter of your drive.

3. Select **OK** and then select **Finish**.
4. Although Windows has already found the driver diskette in a previous step, you might be prompted for its location. Enter **A:** if installing from a diskette or the letter of the CD-ROM drive.

Note: Some of the files on the diskette are located in the DOS subdirectory. If necessary, you will have to supply this subdirectory to get additional files copied onto your computer.

5. At this point, Windows 95 might prompt you for network names. Type your computer's name and workgroup. Consult your system administrator if you do not know this information. Select **OK** to continue.
6. The driver files will be copied at this point. Windows might prompt you for the Windows 95 CD-ROM in order to install its default network protocols and services. Make sure that the location of your Windows 95 installation files (for example, D:\ or D:\WIN95 or C:\WINDOWS\CATROOT) appears in the entry and select **OK**. You might also be prompted again for the location of the driver files. Enter the appropriate location again as described previously.
7. After the files have been copied, a dialog box will display the following message:

To finish setting up your new hardware, you must restart the computer. Do you want to restart your computer now?

Remove the driver diskette or CD-ROM from the computer and select **Yes**.

8. Installation is now complete.
Check for the following conditions to determine whether the adapter is working correctly and whether installation has been completed successfully:
 - The device driver files loaded successfully.
 - The Device Manager (System control panel applet) reports that the device is working correctly.
 - The adapter LEDs indicate normal operation: green ON, amber OFF.

If you experience problems, go to Chapter 4. Problem Solving.

Windows 98

Windows 98 ships with a device driver for the IBM Token-Ring PCI Family Adapter. Although the device driver will function with your adapter, it is strongly recommended that you upgrade to the driver included with this product. Use the following procedure to install the latest driver instead of the driver supplied with Windows 98.

Installing the Updated Driver

Use this procedure if Windows 98 automatically installed the default driver for your IBM Token-Ring PCI Family Adapter. This is necessary if, for example, your installed Windows 98 on a computer with the adapter installed in the system. This procedure assumes that the IBM Token-Ring PCI Family Adapter has already been installed in the computer.

1. Select **Start ► Settings ► Control Panel**. This will display the Control Panel.
2. Double-click **System**. This loads the System Properties dialog.
3. Select **Device Manager**.
4. In the Device Manager, expand the Network adapters section by selecting the **+** that appears to the left of the words Network adapters. Select the entry labeled **IBM PCI Token-Ring Adapter,NDIS4**, and then select **Properties**.
5. Select **Driver** to display the driver information. On this page, select **Update Driver**.
6. At this point, the Update Device Driver Wizard dialog opens. This dialog should contain the following text:

This wizard searches for updated drivers for:
IBM PCI Token-Ring Adapter,NDIS4.

Select **Next** to continue.

7. On the next page, select **Search for the best driver for your device** and then select **Next**.
8. The next page of the wizard will ask where you would like to look for the device driver.
 - If you are installing the device driver from the product CD-ROM, insert the CD-ROM into the CD-ROM drive and make sure that the **CD-ROM drive** checkbox is checked.
 - If you are installing from a diskette that you built from the CD-ROM or from the Web, insert the diskette and make sure that the **Floppy disk drives** checkbox is checked.
9. Select **Next** to continue. Windows should find an updated device driver on the diskette or the CD-ROM. Make sure that **The updated driver** is selected on the page and select **Next**.
10. The next page of the wizard should confirm that the hardware and device driver are found. Select **Next** again to begin copying files.

Windows might prompt you for the driver diskette. Type the letter of your drive. Windows might also prompt you for the Windows 98 CD-ROM in order to install its default network protocols. Make sure that the location of your Windows 98 installation files (for example, D:\ or D:\WIN98 or C:\WINDOWS\CATROOT) appears in the entry and select **OK**.
11. The wizard should report after the files have finished copying that Windows has finished installing an updated driver for your hardware device.

Select **Finish** to continue.

12. Windows returns you to the adapter properties page. Select **Close** to continue.
13. Next, you are returned to the Device Manager page. Select **Close** again to complete the process.
14. Installation is now complete. You might want to reboot your computer to make sure that all components of the driver loaded correctly.

Check for the following conditions to determine whether the adapter is working correctly and whether installation has been completed successfully:

 - The device driver files loaded successfully.
 - The Device Manager (System control panel applet) reports that the device is working correctly.
 - The adapter LEDs indicate normal operation: green ON, amber OFF.

If you experience problems, go to Chapter 4. Problem Solving.

If Windows 98 Is Already Installed

Use this procedure if you are installing the IBM Token-Ring PCI Family Adapter in a computer which already has Windows 98 running. This procedure assumes that the IBM Token-Ring PCI Family Adapter has already been installed in the computer.

1. When Windows 98 boots, it will detect the new hardware and display the Add New Hardware Wizard dialog. This dialog should contain the following text:

```
This wizard searches for new drivers for:  
IBM PCI Token-Ring Adapter,NDIS4.
```

Select **Next** to continue.

2. On the next page, select **Search for the best driver for your device** and then select **Next**.
3. The next page of the wizard will ask where you would like to look for the device driver.
 - If you are installing the device driver from the product CD-ROM, insert the CD-ROM into the CD-ROM drive and make sure that the **CD-ROM drive** checkbox is checked.
 - If you are installing from a diskette that you built from the CD-ROM or from the Web, insert the diskette and make sure that the **Floppy disk drives** checkbox is checked.
4. Select **Next** to continue. Windows should find an updated device driver on the diskette or the CD-ROM. Make sure that **The updated driver** is selected on the page and select **Next**.
5. The next page of the wizard should confirm that the hardware and device driver are found. Select **Next** again to begin copying files.

Windows might prompt you for the driver diskette. Type the letter of your drive.

Windows might also prompt you for the Windows 98 CD-ROM in order to install its default network protocols. Make sure that the location of your Windows 98 installation files (for example, D:\ or D:\WIN98 or C:\WINDOWS\CATROOT) appears in the entry and select **OK**.
6. The wizard should report after the files have finished copying that Windows has finished installing the software that your new hardware device requires.

Select **Finish** to continue.

7. A dialog box will display the following message:

To finish setting up your new hardware, you must restart your computer. Do you want to restart your computer now?

Remove the diskette or CD-ROM from your computer and select **Yes**.

8. Installation is now complete.

Check for the following conditions to determine whether the adapter is working correctly and whether installation has been completed successfully:

 - The device driver files loaded successfully.
 - The Device Manager (System control panel applet) reports that the device is working correctly.
 - The adapter LEDs indicate normal operation: green ON, amber OFF.

If you experience problems, go to Chapter 4. Problem Solving.

Remote Unattended Installation of Windows 95, Windows 98 and Windows NT

Instructions for this environment are on this CD-ROM and can be read with your Web browser. The file is x:\web\essmain.htm where x is your CD-ROM drive letter. Select the appropriate adapter and then select **Downloads**. Select the appropriate operating system to expand the list of packages. Then select **Remote Unattended Install (RUI)**.

Novell IntranetWare Client for Windows NT

1. If the NDIS driver is not already installed, follow the instructions in “Windows NT Version 4.0” on page 27 or “Windows NT™ Version 3.51” on page 26. At step 11 of those instructions, make sure that you select the appropriate protocols and services to connect to the network.

Note: If you are connecting to a Novell server through IPX, you need to install the NWLink IPX/SPX Compatible Transport protocol and also the Client Service for NetWare service under the Services ► Workstation tab.

2. Download IntranetWare Client TM for Windows NT v4.11a or higher from Novell’s support.novell.com website. Unzip the downloaded file to a local directory.
3. Run I386\SETUPNW.EXE from the directory where you placed the files.
4. Select **YES** or **NO** to respond to the Novell License Agreement.
5. You might get a message indicating that the Microsoft Client Service for NetWare is installed and will be removed. If so, respond **Continue**.
6. Installation is complete when you see the Installation Complete panel.
7. Reboot and start Windows NT to connect and login to your server.

Novell Client for Windows 95

(Previous version is IntranetWare Client for Windows 95.)

Note: You will need the Windows 95 diskettes or CD-ROM to complete this installation.

If you are installing on a workstation that already has Windows 95 installed using Novell IntranetWare Client Version 2.2 for Windows 95, use the following procedure.

Note: IntranetWare Client Version 2.2 for Windows 95 or Novell Client Version 2.5 for Windows 95 can be downloaded from Novell on the Web at <http://support.novell.com>.

If you are upgrading from the NetWare DOS Requester (VLM) client or if you do not have any network client installed, you need to have the Windows 95 CD-ROM or diskettes or the Windows 95 .CAB files.

1. If the NDIS driver is not already installed, follow the instructions in “Windows 95” on page 28.
2. After downloading the code, run the installation program (SETUP.EXE) for Novell IntranetWare Client Version 2.2 for Windows 95 or Novell Client Version 2.5 for Windows 95.

3. Select **Yes** or **No** to respond to the Novell License Agreement.

4. Select **Start** to begin the installation.

If you are prompted to select a adapter, select one that matches your hardware (this step might not be necessary, as you should have already selected the adapter in the first step).

5. If you do not need to customize your installation, select **Reboot**.
6. If you want optional features or need to configure your workstation, select **Customize**. Then select **Reboot**.

Windows for Workgroups with NDIS 3

Note: Refer to Microsoft documentation for the general procedure regarding installation of network drivers for Windows for Workgroups.

1. Insert the CD-ROM or the NDIS Drivers diskette into the appropriate drive.
2. Double-click the Network group icon from the Program Manager window.
3. Double-click the Network Setup icon.
4. Select **Drivers** and then **Add Adapter...**
5. Select **Unlisted or updated network adapter** and then **OK**
6. Enter **X:WFW**, where *X* is your drive letter. Select **OK**.
7. Select **CLOSE**.
8. Select **OK**.
9. You will be prompted to reinstall specific network-related files. Reinstall them as needed.
10. You will also be prompted to insert the Windows for Workgroups program application diskettes or CD-ROM. Follow the instructions.
11. Select **OK** for any messages regarding updates to the SYSTEM.INI and PROTOCOL.INI files.
12. When prompted to restart your computer, select **RESTART COMPUTER**.
Windows for Workgroups will automatically restart your computer and the driver will be loaded.
13. At system startup, check for the following conditions to determine whether you have successfully installed the adapter:
 - The device driver files loaded successfully. There are no error messages.
 - The adapter LEDs indicate normal operation. See “Understanding the Adapter LEDs and Labels” on page 39.
 - You are able to log on and communicate with the network.If you experience problems, go to “Chapter 4. Problem Solving” on page 37.

Chapter 4. Problem Solving

This chapter contains procedures that help you troubleshoot problems and optimize performance of your adapter.

Start of Troubleshooting Process

If you were not able to complete the installation procedures successfully or your adapter is not operating correctly, use the following steps to start the troubleshooting process:

- If yours is the first station on the ring, make sure that AutoSense is disabled.
- Use the following table to locate the symptom that best describes the problem.

Symptom	Solution
Problem with loading the drivers	"Solving Problems with Driver Installation" on page 39
Problem indicated by the adapter LEDs	"Understanding the Adapter LEDs and Labels" on page 39
Problem with the adapter operation	"Adapter Diagnostics" on page 42
Unable to communicate with the network	"Solving an Adapter Communication Problem" on page 37

The following sections are presented:

Section	Page
Solving an Adapter Communication Problem	37
Tech Tips and Frequently Asked Questions	38
Other Performance Enhancements	38
PCISSETUP	38
Solving Problems with Driver Installation	39
Understanding the Adapter LEDs and Labels	39
Understanding the Adapter Labels	41
Adapter Diagnostics	42
Questions, Problems?	43
World Wide Web	43

Solving an Adapter Communication Problem

Check the following list of possible causes if the adapter is unable to communicate on the network but other stations on the network are able to communicate:

1. Verify that the appropriate cable is connected to the adapter and to the network. See "Adapter Cable" on page 8 for a description of the compatible cables.
2. Verify that the adapter is firmly seated in the expansion slot.
3. Verify that the setting for the adapter's Data Rate option matches the data rate of the network, or that the data rate has been set to AutoSense if yours is not the first station on the ring. Run the software configuration again to determine the current setting.
4. Replace the adapter cable with one that is known to be good.

Tech Tips and Frequently Asked Questions

To find tips about specific hardware and software situations, see `x:\lessmain.htm` on the CD-ROM.

Other Performance Enhancements

There is a white paper on this subject on the Web at www.networking.ibm.com/per/per10.html.

PCSETUP

The PCSETUP program is provided as an executable program on the CD-ROM in the `x:\pcsetup` directory.

The program looks for specific system chips based on their PCI Vendor ID and Device ID. Based on which chips are found, modifications are made to specific bits within that chip's PCI configuration registers.

If you have a different PCI adapter that requires that PCSETUP be installed on your machine, and you are adding a IBM Token-Ring PCI Family Adapter, you might need to replace the PCSETUP file installed in your system with the PCSETUP file on the CD-ROM. In either case, you should use the PCSETUP file with the higher version number.

PCSETUP modifies the BIOS setup for the adapter in specific systems.

If you need to install a PCSETUP file, use the following instructions.

DOS, Novell, Windows, or Windows 95 (adapter driver not in CONFIG.SYS)

1. Insert the CD-ROM in the drive.
2. Copy `X:\PCSETUP\PCSETUP.EXE` to the root directory of the diskette from which the system boots where X is your CD-ROM drive.
3. Make the following line the first executable line in the AUTOEXEC.BAT file:
`PCSETUP`

DOS, Novell, Windows, or Windows 95 (adapter driver in CONFIG.SYS)

1. Insert the CD-ROM in the drive.
2. Copy `X:\PCSETUP\PCSETUP.DOS` to the root directory of the diskette from which the system boots where X is your CD-ROM drive.
3. Make the following line the first executable line in the CONFIG.SYS file:
`DEVICE=PCSETUP.DOS`

OS/2

1. Insert the CD-ROM in the drive.
2. Copy `X:\PCSETUP\PCSETUP.OS2` to the root directory of the disk from which the system boots where X is your CD-ROM drive.
3. Make the following line the first executable line in the CONFIG.SYS file:
`DEVICE=PCSETUP.OS2`

Windows NT

1. Insert the CD-ROM in the drive.
2. From the File pull-down menu, select **Run**.
3. Type X:\PCSETUP\PCSETNT in the path entry field where X is your CD-ROM drive. Then, select **OK**. PCSETNT.BAT will install PCSETUP.SYS as a device driver that will be loaded each time the system is started.

Solving Problems with Driver Installation

- Ensure that you performed the installation procedures correctly.
- In the following table, locate the row that describes the network operating system or network application on the computer and perform the recommended actions.

Environment	Message Type and Action
Novell NetWare Server	<ul style="list-style-type: none">• Message prefix IBMTRPO: See Appendix F. Novell NetWare Server and LAN Client Driver Messages. This appendix contains explanations and recommended actions for each message.• Novell NetWare messages: Refer to your Novell NetWare documentation to determine the appropriate action
OS/2 with MPTS	Check LANTRAN.LOG, usually found in the subdirectory \IBMCOM, for messages. LAN Server users can use the NET ERROR function to view the error log. <ul style="list-style-type: none">• Message prefix LA1 or reference to IBMTRP: Go to Appendix D. NDIS 2 Device Driver Messages.
Other OS/2 stations	Refer to the documentation provided with the network operating system or network application that you used to install the adapter and protocol driver.
LAN Client	See Appendix F. Novell NetWare Server and LAN Client Driver Messages.
DOS NDIS 2	See Appendix D. NDIS 2 Device Driver Messages.
Windows NT	Check for messages from the IBMTRP service using the Windows NT Event Viewer tool.

Understanding the Adapter LEDs and Labels

Figure 4 on page 40 and Table 3 on page 40 describe the LEDs and labels located on the bracket of the adapter.

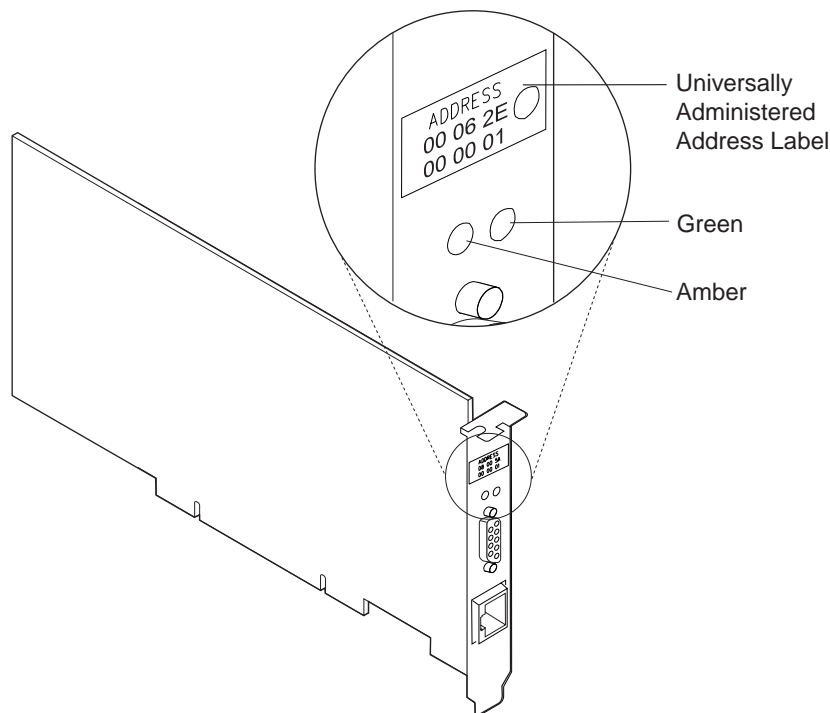

Figure 4. The adapter LEDs and Labels

The LEDs provide information useful for monitoring the status of the adapter and for problem solving. If the green LED is on and the amber LED is off, the adapter is operating correctly. If the amber LED is blinking and the green LED is on, a problem with the adapter has been detected. Table 3 indicates the sequence that will be displayed when the computer is started and the adapter reaches the open state successfully. Some of the states might be too brief to observe. Table 4 on page 41 lists LED states that indicate problems.

Table 3. Startup Sequence of LED States

Amber	Green	Explanation
Blinking	Blinking	<p>Slow blink The adapter is waiting for initialization.</p> <p>Fast blink The adapter has detected a wake-up frame and is attempting to wake up the system. If this state persists, it indicates one of the following problems:</p> <ul style="list-style-type: none"> • The attached PC does not have Wake on LAN enabled. To correct this problem, power on the PC and enable the Wake on LAN feature from the power management system configuration menu. • The Wake on LAN cable is not attached correctly. To correct this problem, ensure that the Wake on LAN cable is properly attached.
Off	Off	The adapter initialization is in progress, or the computer is powered off.

Table 3. Startup Sequence of LED States (continued)

Amber	Green	Explanation
Off	Blinking	The adapter did not detect any problems during its self-diagnostic tests and is waiting to open. If this LED state occurs after the adapter has been opened, this state indicates that the adapter has been closed under software control.
Off	On	The adapter is open and operating correctly.

Table 4. Problems Shown by adapter LED States

Amber	Green	Explanation and Action
On	Off	The adapter self-diagnostic tests failed or there is a problem with the adapter. Action: Go to “Adapter Diagnostics” on page 42 to test the adapter.
Blinking	Off	The adapter is closed due to one of the following conditions: <ul style="list-style-type: none"> • The adapter open failed. • The adapter detected a wire fault. • The adapter failed the auto-removal test. Action: Perform the following procedures, as appropriate: <ol style="list-style-type: none"> 1. Perform “Solving an Adapter Communication Problem” on page 37. 2. Verify that the adapter is configured correctly. 3. If other stations on the network are having problems communicating, contact your network administrator.
Blinking	On	The adapter has detected beaconing or a hard error. Action: Go to “Solving an Adapter Communication Problem” on page 37.
On	On	The adapter has failed before running the self-diagnostic tests. Action: Go to “Adapter Diagnostics” on page 42 to test the adapter.

See the glossary for definitions of the terms used in Table 4.

Understanding the Adapter Labels

The *green dot label* indicates the speeds that this adapter supports over a Token Ring.

The *universally administered address label* contains the adapter’s universally administered address. This is the MAC address that was encoded in the adapter memory at the factory. This 12-digit, hexadecimal address is recorded on the label in groups of two digits from left to right, starting on the first row. In Figure 4 on page 40, the universally administered address is X'00 06 2E 00 00 01' in non-canonical format, with the most significant bit (MSB) first. The universally administered address is unique and is used by network software to distinguish the adapter from others in the network. If you prefer the adapter to be known on the network by a locally administered address, you must configure the device driver or protocol driver to use a locally administered address.

Adapter Diagnostics

Important

To avoid potentially erroneous results, you should always perform a power-on reboot of your computer before running the diagnostics.

The LANAIDC and Diagnostics diskette must be created before you run the following procedure. Point your Web browser to x:\weblessmain on the CD-ROM where x is your CD-ROM drive. Select your adapter and click **Downloads**. Select **Diagnostics and LANAIDC**. Copy the diagdisk.exe file and run it to create the LANAIDC and Diagnostics diskette.

Use the following procedure to test your adapter:

1. Insert the LANAIDC and Diagnostics diskette in drive A and reboot your computer.

If the system will not boot with the adapter installed, but will boot with the adapter removed, skip to step 6 on page 43.

To run 4/16 Mbps diagnostics: at the DOS 7.0 Boot Menu select **IBM PCI Token-Ring Extended Diagnostics for 4/16 Mbps operation**. Go to step 2.

To run 100 Mbps diagnostics: at the DOS 7.0 Boot Menu select **IBM PCI Token-Ring Extended Diagnostics for 100 Mbps operation**. Go to step 5 on page 43.

Note: If there is more than one adapter installed in your computer, select the specific one to be tested. A selection menu is listed identifying each adapter by its universally administered address. For 4/16 Mbps operation, use the cursor keys or the mouse to select the adapter for test. For 100 Mbps operation, enter the correct number of the adapter for test.

2. Connect the adapter to the network and press the **Test** (Enter) key. There are two test options: wrap test and on-ring test.
The wrap test tests the adapter and cable through the hub or concentrator, or through a wrap plug attached to the cable.
The on-ring test requires that the adapter be connected to a network with other adapters, so the ring speed of the network can be automatically sensed. If the adapter is the only one in the network, the on-ring test will fail.
3. If the test indicates that there is no adapter in the system, or that diagnostics cannot be run:
 - a. Check that the adapter is correctly seated in the slot.
 - b. Make sure that the LEDs blink alternately amber and green after you power up your computer.
 - c. See Table 3 on page 40 for LED states.
 - d. Run the adapter diagnostics again. If the tests are completed successfully, and your computer still is not communicating contact your network administrator.
4. If the wrap test and on-ring test run without errors, the adapter is ready for use. Exit the diagnostic program, and follow the directions for reactivating the computer.

If an error occurs, record any messages that appear, record the LED sequences, and contact your network administrator.

Note: This procedure does not verify that the data rate of the device driver setting matches the data rate of the LAN segment.

Note: If more than one adapter is in your computer, and if you have not yet run the diagnostics, the 4/16 diagnostics will reboot your computer, after updating for the correct number of adapters.

5. Disconnect the adapter to be tested from the 100-Mbps port. Connect a wrap plug into the RJ-45 jack. Enter the number of the adapter to be tested. The 100-Mbps diagnostics will perform several tests on the adapter and through the wrap plug to verify the operation of the adapter.
6. If the test indicates that there is no adapter in the system, or that diagnostics cannot be run:
 - a. Check that the adapter is correctly seated in the slot.
 - b. Make sure that the LEDs blink alternately amber and green after you power up your computer.
 - c. See Table 3 on page 40 for LED states.
 - d. Run the adapter diagnostics again. If the tests are completed successfully, and your computer still is not communicating contact your network administrator.
7. If the 100-Mbps diagnostics run without errors, the adapter is ready for use. Exit the diagnostics program and follow the instructions to reboot the computer. If an error occurs, record any messages that appear, record the LED sequences, and contact your network administrator.

Questions, Problems?

See the README.1ST file on this CD-ROM. It contains an index of the readme files containing the latest information about this product.

World Wide Web

You can download the latest code from the World Wide Web.

On a Web browser:

www.ibm.com/networking/support

IBM Product Support

1-800-237-5511	IBM Support Services
1-800-772-2227	IBM HelpCenter®
1-800-565-3344	HelpPC (Canada)

Appendix A. CD-ROM Content and Software Packages

The CD-ROM contains adapter drivers, supporting applications, publications, technical tips, and frequently asked questions related to the IBM Token-Ring PCI Family Adapters. A navigational tool is provided to assist in accessing the contents of the CD-ROM. This tool can be launched by opening the file `x:\web\essmain.htm` (where `x` is the letter of your CD-ROM drive) in a Web browser. Release date information can be obtained from the CD-ROM by selecting your adapter from the section CD-ROM - release date information. However, the IBM Networking Web site might offer more current information. If you have internet access, you can obtain the most current drivers and information by selecting your adapter from the section IBM Networking Web site - current information.

- *User's Guide* and *Features* in HTML and PDF format. See "Product Documentation" on page 46.
- README.1ST file on the \root directory that points to individual readme files.
- Device Drivers that can be installed directly from the CD-ROM during the device driver install process. They are located in the following directories:

Operating System	Directory
Windows 9x	\ (root)
Windows NT	\ (root)
Novell NetWare Server and Client	\NOVELL\NETWARE
Novell NetWare DOS Requester (16-bit)	\NOVELL\DOS
Novell NetWare OS/2 Requester (16-bit)	\NOVELL\OS2
OS/2	\ (root)
DOS	\DOS
Windows for Workgroups	\WFW

- LAN Client files that can be installed directly from the CD-ROM during the LAN Client installation process.
- Self-expanding PACKAGE and IMAGE files.

Table 5 lists packages that are available on the Web and on the CD-ROM. Table 6 on page 46 lists diskette images that are available on the Web and on the CD-ROM. They can be obtained using the navigation tool already mentioned. Select the Web link for the latest version of the file, or select the CD-ROM link to copy the file directly from the CD-ROM. The files are located on the CD-ROM at `x:\web\ftplan~1.ftp` (where `x` is your drive letter).

Software Packages

The package files can be executed to expand the files to a hard disk, or to a diskette where noted with an asterisk (*). The directory structure is maintained as it exists on the CD-ROM.

Table 5. Software Packages

Package	Description	Executable
CD-ROM	Complete CD-ROM content	CDIMAGE.EXE

Table 5. Software Packages (continued)

Package	Description	Executable
Device Drivers (*)	DOS and Windows 3.1x (NDIS 2) Novell NetWare DOS Requester (16-bit) Novell NetWare Server and Client OS/2 (NDIS) Windows 95/98/NT (version 5.11b) Windows 95/98/NT (version 5.12) Windows for Workgroups	DOSNDISP.EXE DOSODIP.EXE NETWAREP.EXE OS2NDISP.EXE WIN32PKG.EXE 512LOGO.EXE WFWPKG.EXE
Documentation - HTML and PDF	User's Guide Features Guide	PUBS2.EXE EXTPUBS.EXE
IBM LAN Client	IBM LAN Client - Complete package	LCPKG.EXE
LAN Adapter Management Agents	OS/2 Windows NT and Windows 9x	DMIOS2.EXE DMIWIN.EXE
PCI Setup (*)	PCI Setup Utility	PCIPKG.EXE
RPL (*)	Remote Program Load (RPL/DHCP/PXE)	RPLPKG.EXE
Tivoli Management Agents (*)	Windows 3.x Windows 9x Windows NT OS/2 NetWare 3.x NetWare 4.x and 5.x	TMAW3X.EXE TMAW9X.EXE TMAWNT.EXE TMAOS2.EXE TMANW3X.EXE TMANW4_5.EXE

Diskette Images

Run these diskette image files to create diskettes. Each image file will create a single diskette.

Table 6. Diskette Images

Image	Description	Executable
CID for OS/2	Configuration, Installation, and Distribution diskette	CID.EXE
Diagnostics	Diagnostics and LANAIDC diskette	DIAGDISK.EXE
LAN Adapter Management Agents	OS/2 - Diskette 1 OS/2 - Diskette 2 Windows 95/98/NT - Diskette 1 Windows 95/98/NT - Diskette 2 Windows 95/98/NT - Diskette 3	DMIOS2A.EXE DMIOS2B.EXE DMIWINA.EXE DMIWINB.EXE DMIWINC.EXE
IBM LAN Client	IBM LAN Client - Diskette 1 IBM LAN Client - Diskette 2 IBM LAN Client - Diskette 3 IBM LAN Client - Diskette 4	LCDISK1.EXE LCDISK2.EXE LCDISK3.EXE LCDISK4.EXE
PCI Flash	PCI Flash Update diskette	PCIFLASH.EXE
RUI	Remote Unattended Install diskette for Windows 95/98/NT	RUI.EXE

Product Documentation

Complete product documentation is available for downloading from the CD-ROM and the Web in both PDF and HTML formats. The HTML version can also be viewed directly from your Web browser. Two documents are provided. The *User's Guide* includes hardware and software installation instructions, troubleshooting tips,

device driver parameters and error messages, and a description of IBM's Alert on LAN function. The *Features Guide* provides detailed information about Remote Program Load, LAN Client, LAN Adapter Management Agent, Route Switching, Class of Service, and Redundant NIC.

To access the download versions, insert the CD-ROM into the CD-ROM drive of your computer and point your Web browser to x:\web\essmain (where x is your CD-ROM drive letter). Select your adapter type and then **Downloads**. Select **Target Operating System** and then select the *User's Guide* or the *Features Guide*. Select the package name that appears. Select **Save as...** and choose the path to the directory where you want to copy the package file. Select **OK** to download the package file. Go to the directory where the package was stored and run the package file to expand the files.

The *User's Guide* in PDF format is stored in the file userguid.pdf. The *Features Guide* in PDF format is stored in the file feature.pdf. The corresponding HTML versions are in userguid.htm and feature.htm.

To view the documentation directly from the CD-ROM, insert the CD-ROM into the CD-ROM drive of your computer and point your Web browser to x:\web\essmain (where x is your CD-ROM drive letter). Under CD-ROM - release date information, select your adapter type and then the documentation that you want to view.

Appendix B. About Alert on LAN

Alert on LAN is an architecture that provides system monitoring in all power states (On, Sleep, Off) and has the ability to send alerts or status to a remote management console via the LAN in any of these states. From a system perspective, the required components of Alert on LAN are a network connected PC, motherboard monitoring capabilities on the PC, and a remote management console. The IBM 16/4 Token-Ring PCI Adapter 2 with Wake on LAN provides the network connection for the PC and will interface to the PC monitoring subsystem on the motherboard. The adapter also functions as a normal adapter for the PC.

Features

Alert on LAN monitors environmental, security and software functions of the client PC. These functions include the following:

- Environment
 - Power supply voltage problem SOS alert in Full on and Sleep states
 - Temperature out of range SOS alert in Full on and Sleep states
- Security
 - Chassis intrusion alert: A switch on the cover generates an event when the cover is removed.
 - Processor missing alert: When the CPU is unplugged from its socket, an alert event is generated.
 - Presence detection via programmable client heartbeat: The client is periodically polled by the server to determine its presence.
 - Network disconnect event capture: When the LAN cable is removed from the PC, an alert event is generated.
- Software
 - Remote OS hang/System crash SOS alert
 - Remote NMI SOS alert
 - Remote ECC double bit error SOS alert
 - Wake On LAN successful indication message
 - Power on self test (POST) hang via watchdog timer
 - Remote reporting of POST error codes
 - PreBoot Execution Environment with LSA/RPL
 - Reports status to remote management server irrespective of CPU state
 - Reports status in periodic heartbeat alert (Full On, Sleep, Off)

Alert on LAN enables systems management in the following ways:

- When a computer is physically connected to the network but is powered off, Alert on LAN aids in protecting systems from theft and tampering by
 - Monitoring the physical presence of a system through a programmable heartbeat. If this heartbeat stops, it can serve to alert administrators of disconnection of a computer from the network.
 - Monitoring for unauthorized tampering of the computer. If the chassis cover is removed, a cover tamper alert is generated, helping reduce loss of vital components such as memory, CPU, or hard drive.
 - Monitoring disconnection or reconnection of the network cable. For example, if someone disconnects a computer from the network to move it to a new

location, when the computer is reconnected, an alert is generated. It can also help track when mobile systems are installed.

- During the automated installation of an operating system on a new system or off-hours maintenance of an existing system, Alert on LAN can notify the remote administrator of hardware and software failures:
 - Power On Self Test (POST) has not been successful, indicating a failure to boot.
 - The system operating system is not responding. This feature is beneficial for unattended systems like servers, kiosks, or computers being remotely serviced during off-hours.
 - Alert on LAN also provides alerts for critical hardware failures such as voltage fluctuations and high temperature even when the operating system can not respond.

Appendix C. NDIS 2 Device Driver Parameters

Table 7. DOS and OS/2 NDIS Device Driver Parameters in *PROTOCOL.INI*

Parameter	Explanation
NetAddress	<p>Use this parameter to specify a locally administered address for the adapter. The address must be enclosed in double quotes (" ") and be unique among all the addresses on the network.</p> <p>The adapter can be known on the network by its universally administered address (the address encoded in the adapter's memory at the factory) or a locally administered address (a unique, user-assigned address).</p> <p>The universally administered address is the default value. That address appears on the adapter bracket. See Figure 4 on page 40 for an illustration.</p> <p>Valid values: "400000000000" to "7FFFFFFFFFFF" in hex</p>
DataRate	<p>Used for configuring the ring speed of the adapter. It is recommended for servers that the DataRate be set to M16 or M4, and clients be set to Auto. This parameter is ignored for 100 Mbps network operation.</p> <p>Valid values:</p> <p>AUTO AutoSense – automatic ring-speed detection. Note: The adapter will not function with AutoSense if it is the first one on the ring. AutoSense is not designed for changing ring speed while the adapter is operational. It is usually necessary to reload the driver.</p> <p>M16 16-Mbps ring-speed operation.</p> <p>M4 4-Mbps ring-speed operation.</p> <p>The default is AUTO.</p>
EnableTxEofInt	<p>This parameter specifies whether the Transmit End of Frame Interrupt is enabled.</p> <p>Valid values:</p> <p>Yes Indicates that the interrupt will be recognized by the interrupt handler.</p> <p>No Indicates that the interrupt will not be recognized by the interrupt handler. This value is preferable in some environments (such as a server environment) to reduce the number of times the interrupt handler is invoked. This can result in reduced CPU utilization and increased performance.</p> <p>The default is Yes.</p>
MaxTransmits (OS/2 only)	<p>This parameter specifies the maximum number of transmit queue entries. The value should be set high enough to accommodate the sum of all MaxTransmits for all protocol drivers using the adapter concurrently.</p> <p>Valid values: 1 to 128</p> <p>The default is 31.</p>

Table 7. DOS and OS/2 NDIS Device Driver Parameters in PROTOCOL.INI (continued)

Parameter	Explanation
MaxTxFrameSize (OS/2 only)	<p>This parameter specifies the maximum frame size that can be transmitted on the LAN. The parameter value serves as an upper limit. The actual maximum frame size might be smaller. The maximum frame size supported by the NDIS device driver is the lesser of the following values:</p> <ul style="list-style-type: none"> • The value of this MaxTxFrameSize parameter • Total Receive Buffer Area (see the MinRcvBufs parameter) • The physical frame size capacity of the network (4500 bytes for 4-Mbps Token Rings and 18 200 bytes for 16-Mbps and 100-Mbps Token Rings) <p>Do not count the 4 bytes of FCS defined for a frame when setting this parameter value.</p> <p>In some environments, performance can be increased by operating server and client at larger frame sizes. Protocol frame size should be adjusted if this parameter is changed. Note: Some Token-Ring switches support a maximum frame size of 4500.</p> <p>Valid values: 14 to 18 000</p> <p>The default is 4500.</p>
MinRcvBufs (OS/2 only)	<p>This parameter specifies the minimum number of receive buffers that are allocated. The Total Receive Buffer Area for the adapter is calculated using the following formula: Total Receive Buffer Area = MinRcvBufs × RcvBuffSize Note: To receive the maximum length frame that is supported by the attached network, the Total Receive Buffer Area must be larger than the maximum frame size that is allowed for the network, which is 4500 bytes for 4-Mbps Token Rings and 18 000 bytes for 16-Mbps and 100-Mbps Token Rings).</p> <p>A smaller Total Receive Buffer Area will use less system memory but will correspondingly reduce the size of the largest frame that can be received by the NDIS device driver. The maximum frame size supported by the driver can be further limited by the MaxTxFrameSize parameter.</p> <p>Valid values: 1 to 512</p> <p>The default is 20.</p>
RcvBuffSize (OS/2 only)	<p>This parameter specifies the size of each receive buffer.</p> <p>Valid values: 256 to 18 000</p> <p>The default is 2252.</p>
FullDuplex	<p>This parameter permits the device driver to activate Token-Ring full-duplex operation if supported by the network. The MaxTxFrameSize parameter may need to be adjusted separately, depending on network requirements.</p> <p>Valid values:</p> <p>Yes Permits full-duplex operation.</p> <p>No Prohibits full-duplex operation.</p> <p>The default is Yes.</p>

Table 7. DOS and OS/2 NDIS Device Driver Parameters in *PROTOCOL.INI* (continued)

Parameter	Explanation
LoopBack	<p>Determines whether or not the adapter will copy a frame that it is transmitting if the destination address is recognized by the adapter.</p> <p>Valid values:</p> <p>Yes Indicates that transmit frames whose destination is this adapter will be transmitted and then received by the adapter.</p> <p>No Indicates that transmit frames whose destination is this adapter must be looped back by the protocol stack.</p> <p>The default is No.</p>
TxPriMax	<p>This parameter specifies the value of the maximum token access priority that will be allowed for frames sent on the high-priority transmit channel. High-priority transmit frames whose Frame Control priority value exceeds the value of this parameter will have their token access priority reduced to the value specified by this parameter. Frame Control is a field in the IEEE 802.2 Logical Link Control (LLC) header.</p> <p>Valid values: 0 to 6</p> <p>The default is 6.</p>
TxPriThresh	<p>This parameter specifies the frame priority value that will be used to transmit on the adapter's high-priority transmit queue. IEEE 802.2 LLC frames that contain a frame priority setting (in the Frame Control field) that is equal to or greater than the value of this parameter are treated as high-priority frames.</p> <p>Valid values: 1 to 6</p> <p>The default is 1.</p>
LLCOnly	<p>This parameter indicates whether only LLC frames should be copied by the adapter when it is running in promiscuous copy mode. If this parameter is set to Yes, no MAC frames will be copied while in promiscuous copy mode.</p> <p>Valid values:</p> <p>Yes Copy only LLC frames.</p> <p>No Copy all frames on the ring.</p> <p>The default is No.</p>
EUIDelay (OS/2 only)	<p>This parameter should always be set to zero. It is intended for debug use.</p> <p>Valid values: 0 to 10</p> <p>The default is 0.</p>

Table 7. DOS and OS/2 NDIS Device Driver Parameters in *PROTOCOL.INI* (continued)

Parameter	Explanation
RTSWMode (OS/2 only)	<p>This parameter indicates whether the driver should enable code that attempts to send routable traffic directly to a destination rather than through the router. This can improve the performance of these connections and reduce the workload at the router. If the value is Disable, all routable frames will be sent through the router.</p> <p>Valid values:</p> <p>Auto Automatically determines whether to use Peer or Client mode.</p> <p>Peer Communicates with a peer destination station to establish a direct path.</p> <p>Client Uses an MSS server to determine the direct path.</p> <p>Disable Deactivates the route switching function for this adapter.</p> <p>The default is Disable.</p>
RTSWTableSize (OS/2 only)	<p>This parameter specifies the number of entries allowed in the route table for route switching support. This should be set equal to or greater than the number of remote stations that this station will send data to using routable frames (for example, TCP/IP). If it is set too low, some of the traffic that could be sent directly will instead be sent through the router.</p> <p>Valid values: 16, 32, 64, 128, 256, 512, 1024</p> <p>The default is 16.</p>
RTSWSubnetMask (OS/2 only)	<p>This parameter contains a character string specifying the IP Subnet Mask for the IP subnet to which this adapter will attach. This value is entered as an IP dotted decimal value, for example, 255.255.255.0. This is a mandatory parameter when the RTSWMode parameter is set to Auto or Peer.</p> <p>Valid values: xxx.xxx.xxx.xxx A dotted-decimal IP network number (15 characters maximum).</p> <p>Disable When not in use.</p> <p>The default is Disable.</p>
RTSWHoldingTime (OS/2 only)	<p>This parameter specifies the Route Switching information holding time value. This determines how often a remote station must refresh its Route Switching information which pertains to this station.</p> <p>Valid values: 2 to 20</p> <p>The default is 20.</p>

Table 7. DOS and OS/2 NDIS Device Driver Parameters in PROTOCOL.INI (continued)

Parameter	Explanation
TCPPortRangeN (OS/2 only)	<p>This represents a set of parameters which designates the transmit frame priority value for a specified TCP port range. N is 1, 2, 3, 4, or 5. The format of this 9-digit hexadecimal string is:</p> <p style="padding-left: 40px;">PortNumber PortNumber PriorityValue</p> <p>where each PortNumber is a four-character hex value and PriorityValue is a one-character hex value. The two PortNumber fields define a starting and ending value that make up a range, with the starting value less than or equal to the ending value.</p> <p>Valid values:</p> <p>PortNumber 0x0000 to 0xFFFF</p> <p>PriorityValue 1 to 6</p> <p>There is no default for this parameter.</p>
UDPPortRangeN (OS/2 only)	<p>This represents a set of parameters which designates the transmit frame priority value for a specified UDP port range. N is 1, 2, 3, 4, or 5. The format of this 9-digit hexadecimal string is:</p> <p style="padding-left: 40px;">PortNumber PortNumber PriorityValue</p> <p>where each PortNumber is a four-character hex value and PriorityValue is a one-character hex value. The two PortNumber fields define a starting and ending value that make up a range, with the starting value less than or equal to the ending value.</p> <p>Valid values:</p> <p>PortNumber 0x0000 to 0xFFFF</p> <p>PriorityValue 1 to 6</p> <p>There is no default value for this parameter.</p>

```

;Protocol Manager Section
[PROT_MAN]
    Drivername = PROTMAN$

;Section A: Protocol Driver (IBM TCP/IP V1.2 for DOS)
[TCPIP_nif]
    Drivername = TCPIP$
    Bindings = IBMTRP_NIF

;Section B: NDIS Device Driver
[IBMTRP_NIF]
    Drivername = IBMTRP$
    NetAddress = "400000000000"
    DataRate = "M16"
    EnableTxEofInt = "Yes"
    FullDuplex = "Yes"
    TxPriMax = 6
    TxPriThresh = 1
    LLCOnly = "No"
    
```

Figure 5. Sample PROTOCOL.INI File for a DOS Station Configured for TCP/IP

```

;Protocol Manager Section
[PROT_MAN]
  Drivername = PROTMAN$

;Section A: Protocol Driver (IBM TCP/IP V1.2 for OS/2)
[TCPIP_nif]
  Drivername = TCPIP$
  Bindings = IBMTRP_NIF

;Section B: NDIS Device Driver
[IBMTRP_NIF]
  Drivername = IBMTRP$
  NetAddress = "400000000000"
  DataRate = "M16"
  EnableTxEOFInt = "Yes"
  MaxTransmits = 31
  MaxTxFrameSize = 4500
  MinRcvBufs = 20
  RcvBuffSize = 2252
  FullDuplex = "Yes"
  TxPriMax = 6
  TxPriThresh = 1
  LLCOnly = "No"
  EOIDelay = 0
  RTSWMode = "Disable"
  RTSWTableSize = 16
  RTSWSubnetMask = "Disable"
  RTSWHoldingTime = 20

```

Figure 6. Sample PROTOCOL.INI File for an OS/2 Station Configured for TCP/IP

Appendix D. NDIS 2 Device Driver Messages

This appendix contains messages that can be received from the NDIS device driver. These messages can come from DOS and OS/2 message files. The messages are either displayed or logged to a file.

The term *Port nnnnnnnn* appears in several messages. It is used to identify the adapter's instance and bears **no** relationship to the physical slots in the computer. If this is the only adapter, the number will be 00000000.

LA10001 IBM PCI Token-Ring Adapter, Version xx

Explanation: Information only.

User Action: None.

LA10002 The IBM PCI Token-Ring Adapter UAA (BIA) is xx.

Explanation: Information only.

User Action: None.

LA10003 The IBM PCI Token-Ring Adapter is using an LAA of xx.

Explanation: Information only.

User Action: None.

LA10004 Revision level xx of the adapter is incompatible with this driver version.

Explanation: The Revision ID of the adapter is not one that is supported by this version of the device driver. This correlation is enforced to ensure an appropriate match between the hardware and the device driver software.

User Action: Contact your support personnel for assistance. You might need to upgrade your adapter, use a different version of the device driver, or do both.

LA10005 A device driver initialization error occurred (failure code xx).

Explanation: An unexpected error occurred during initialization of the device driver.

User Action: Shut down the computer correctly and switch OFF the power to the machine. Restart the computer by switching it ON again. If the error persists, contact your support personnel.

LA10006 The configuration parameter xx was specified incorrectly. Its default value will be used.

Explanation: The value of a configuration parameter was incorrectly specified.

User Action: Edit the configuration file (or rerun the configuration program) to specify the correct value within the allowed range. Check the adapter installation instructions for additional information.

LA10007 The configuration parameter values have forced the internal data blocks to exceed the allowed limit.

Explanation: The combination of configuration parameters being used requires more than the 64-KB memory area that is available for this adapter instance to hold its internal control information.

User Action: Lower the value of the MaxTransmits or MinRcvBufs parameters from their current setting to reduce the amount of control block storage required by the device driver. Shut down and restart the computer to activate this configuration change.

LA10008 Unable to register interrupt level xx for this adapter.

Explanation: The hardware interrupt level assigned to this adapter was not able to be registered (*hooked*) by the device driver.

User Action: Check the configuration of your computer, looking for other devices that are assigned the same interrupt level as this adapter. Try removing the conflicting device from the machine and restarting the computer to see if the problem is resolved. If so, determine whether the conflicting device can be left out of the machine, or whether the machine can be reconfigured to resolve the conflict. Note that in most PCI machines, the PCI BIOS assigns certain system resources to the devices found in the computer, including the interrupt level.

LA10010 A hardware failure occurred while attempting to open the adapter.

Explanation: A hardware error was detected when opening the adapter for network operation.

User Action: Run the diagnostics program to isolate the problem, and contact your support personnel. If no problem was identified by the diagnostics, check that the cable is attached securely to both the adapter and the network interface (wall plate). Switch the computer OFF and then ON again to restart the machine. If the problem persists, contact your support personnel.

LA10011 A possible lobe wire failure was detected while attempting to insert into the network.

Explanation: The adapter is not correctly connected to the Token-Ring network.

User Action: Check that the cable is securely attached to both the adapter and to the Token-Ring network. You may need to contact your local network administrator to ensure that the cabling in the building is intact and that the network concentrator to which you are attached is operational. If the error persists, try using a different cable.

LA10012 A signal loss condition was detected while attempting to insert into the network.

Explanation: The Token-Ring network is not functioning correctly.

User Action: Contact your local network administrator to determine the status of your network, or try connecting again at a later time.

LA10013 The lobe wire connected to the adapter is not attached to the network.

Explanation: The adapter is not correctly connected to the Token-Ring network.

User Action: Check that the cable is securely attached to both the adapter and to the Token-Ring network. You might need to contact your local administrator to ensure that the cabling in the building is intact and that the network concentrator to which you are attached is operational. If the error persists, try using a different cable.

LA10014 The configured data rate for the adapter does not match that of the network.

Explanation: The operational speed of the Token-Ring network does not match the configured speed of the adapter.

User Action: Change the setting of the DataRate configuration parameter to match the speed of the network to which the adapter is attached. Your local network administrator should be able to tell you which speed to use.

Setting the DataRate parameter value to Auto will allow the adapter to automatically determine the correct speed setting to use when connecting to the network, provided that this is not the only adapter active on the Token Ring.

This message is relevant for 4-Mbps or 16-Mbps operation only.

Consult the adapter installation instructions for additional information on setting the DataRate parameter.

LA10015 An adapter timeout occurred while attempting to insert into the network.

Explanation: The Token-Ring network is not functioning correctly.

User Action: Contact your local network administrator to determine the status of your network, or try connecting again at a later time.

LA10016 A ring failure condition was detected while attempting to insert into the network.

Explanation: The Token-Ring network is not functioning correctly.

User Action: Contact your local network administrator to determine the status of your network, or try connecting again at a later time.

LA10017 A ring beaconing condition was detected while attempting to insert into the network.

Explanation: The Token-Ring network is not functioning correctly.

User Action: Contact your local network administrator to determine the status of your network, or try connecting again at a later time.

LA10018 A duplicate network address was detected while attempting to insert into the network.

Explanation: The address specified for the NetAddress configuration parameter is being used by another adapter (or ring station) on the network.

User Action: Modify the configuration file to change the NetAddress parameter value being used for this adapter, or remove the NetAddress parameter to allow the adapter's universally administered address to be used.

Contact your local network administrator for assistance with choosing a new NetAddress parameter value, or with having the conflicting adapter removed from the same Token-Ring network as this adapter.

LA10019 A ring parameter failure occurred while attempting to insert into the network.

Explanation: The Token-Ring network is not functioning correctly.

User Action: Contact your local network administrator to determine the status of your network, or try connecting again at a later time.

LA10020 The adapter was forced to remove itself while attempting to insert into the network.

Explanation: The Token-Ring network rejected the attempt by this adapter to connect to it.

User Action: Contact your local network administrator to determine the status of your network, or try connecting again at a later time.

LA10021 A hardware failure occurred while attempting to open the adapter.

Explanation: A hardware error was detected when opening the adapter for network operation.

User Action: Run the diagnostics program to isolate the problem, and contact your support personnel. If no problem was identified by the diagnostics, check that the cable is attached securely to both the adapter and the network interface (wall plate). Switch the computer OFF and then ON again to restart the machine. If the problem persists, contact your support personnel.

LA10022 A hardware failure occurred while attempting to open the adapter.

Explanation: A hardware error was detected when opening the adapter for network operation.

User Action: Run the diagnostics program to isolate the problem and contact your support personnel. If no problem was identified by the diagnostics, check that the cable is attached securely to both the adapter and the network interface (wall plate). Switch the computer OFF and then ON again to restart the machine. If the problem persists, contact your support personnel.

LA10023 The adapter cannot be opened in AutoSense mode if it is the only active station on the network.

Explanation: The adapter DataRate configuration parameter is set to Auto (which is also the default value if the parameter is not specified), but the adapter is the first station to open on the Token-Ring network.

User Action: This adapter is designed to not open onto the attached Token-Ring network if it is configured to use AutoSense detection and if it would have been the first active ring station.

The possible remedies are to try to connect again at a later time when at least one other ring station is active on the network (such as a network server), or to change the configuration value so that the DataRate parameter is set to a specific ring-speed value of M16 or M4 and restart the computer.

Note that setting a specific value of M16 or M4 for the DataRate parameter will cause this adapter to establish the operational speed of the Token-Ring network if it is still the first active ring station.

This message is relevant for 4-Mbps or 16-Mbps operation only.

Check the adapter installation instructions for additional information on setting the DataRate parameter.

LA10024 The adapter attempted to perform a Remote Program Load but failed monitor contention.

Explanation: The adapter was opened as a Remote Program Load (RPL) client, but was unable to locate an RPL server on the network.

User Action: Make sure that there is an active Remote Program Load server on the network and that it is configured to recognize this adapter's address.

LA10025 A network protocol error occurred while attempting to operate the adapter in full duplex mode.

Explanation: The adapter was unable to successfully communicate with a Token-Ring switch when attempting to open for full-duplex operation.

User Action: Check that your full-duplex switch is functioning correctly and that the adapter is correctly connected to it. If this problem persists, contact your support personnel.

LA10026 Unable to automatically change to xx Mbps operation. Please reboot the computer.

Explanation: The adapter attempted to open at one speed, but found the Token Ring operating at another speed. The configuration parameters used during initialization processing, notably the maximum frame size, preclude reliable operation at the new speed, so all additional attempts to open the adapter will be rejected. Rebooting the computer allows the new speed to be factored into the initialization processing without requiring a configuration change in most cases.

User Action: Shut down and restart the computer. Normally, no explicit configuration changes are required to begin operating at the current operational speed of the Token Ring. Optionally, you might be able to change the value of the configuration parameter that specifies the maximum frame size to a value of 4500 or less to eliminate the need to reboot the computer for a similar situation in the future.

LA10027 The adapter opened for token ring, xx Mbps., half duplex.

Explanation: Information only.

User Action: None.

LA10028 The adapter opened for token ring, xx Mbps., full duplex.

Explanation: Information only.

User Action: None.

LA10033 Adapter analysis code is xx.

Explanation: Information only.

User Action: None.

LA10034 Adapter full-duplex operation has now been activated.

Explanation: Information only.

User Action: None.

LA10042 A device driver initialization error occurred (failure code xx).

Explanation: An unexpected error occurred during initialization of the device driver.

User Action: Shut down the computer and switch OFF the power to the machine. Restart the computer by switching it ON again. If the error persists, contact your support personnel.

LA10043 No adapter instances recognized by this device driver were found in PROTOCOL.INI.

Explanation: The PROTOCOL.INI file does not have a section defined by the correct DRIVERNAME= line anywhere within it.

User Action: If you intend to run this device driver, make sure to define a valid network configuration in the PROTOCOL.INI file. If you do not intend to run this device driver, remove its DEVICE= statement from the CONFIG.SYS file.

LA10044 The NDIS 2.0 Protocol Manager could not be opened.

Explanation: An unexpected error occurred when the program attempted to open the Protocol Manager.

User Action: Check the drive and directory to ensure that the Protocol Manager is located in the path specified in the CONFIG.SYS file. If this error persists, consider reinstalling the NDIS 2.0 network support software.

LA10045 Could not find the PROTOCOL.INI file image.

Explanation: An unexpected error occurred when the program attempted to read the PROTOCOL.INI file image through interaction with the Protocol Manager.

User Action: Check the drive and directory to ensure that the Protocol Manager is located in the path specified in the CONFIG.SYS file. Verify that a valid PROTOCOL.INI file exists in the proper location. If this error persists, consider reinstalling the NDIS 2.0 network support software.

LA10046 The required DRIVERNAME parameter was not found in PROTOCOL.INI.

Explanation: The parameter specifying the driver name (DRIVERNAME) was not found in the PROTOCOL.INI file. This parameter is required.

User Action: Change PROTOCOL.INI to specify the proper information.

LA10047 The NetAddress value in PROTOCOL.INI is invalid and will be ignored.

Explanation: The value specified for the network address parameter in PROTOCOL.INI is not valid for one of the following reasons:

- Invalid local station address
- Too long
- Too short
- Contains non-hexadecimal characters
- Not enclosed in double quotation marks

User Action: Remove or correct the NetAddress configuration parameter value. A valid value for this parameter is 12 characters long and must be enclosed in double quotation marks. For Token-Ring adapters, the locally administered address must be within the hex range 400000000000 to 7FFFFFFFFFFFFF.

Make sure not to set the corresponding group address bit, which is the high-order bit in Token-Ring addressing notation.

LA10048 An unrecognized parameter xx was found in PROTOCOL.INI.

Explanation: An unrecognized parameter was found while processing a section of the PROTOCOL.INI file defined for this device driver.

User Action: Correct the parameter name or remove it from PROTOCOL.INI. Refer to the installation manual that came with your adapter for more information on the configuration parameters.

LA10049 The configuration parameter *xx* was specified incorrectly. Its default value will be used.

Explanation: An invalid value was specified for a configuration parameter in the PROTOCOL.INI file. A default value has been substituted.

User Action: Change the PROTOCOL.INI file to specify a valid value for the configuration parameter that is in error. Refer to the installation manual that came with the adapter for more information on the allowable settings for this particular parameter.

The device driver has proceeded with its initialization using a predetermined default value for this parameter.

LA10050 The NDIS 2.0 device driver was not able to register with the Protocol Manager.

Explanation: An unexpected error occurred when the program attempted to register a adapter with the Protocol Manager.

User Action: Check the drive and directory to ensure that the Protocol Manager is located in the path specified in the CONFIG.SYS file. If this error persists, consider reinstalling the NDIS 2.0 network support software.

LA10051 The configuration parameter values have forced the internal data blocks to exceed the allowed limit.

Explanation: The combination of configuration parameters being used requires more than the 64-KB memory area that is available for this adapter instance to hold its internal control information.

User Action: Lower the value of the MaxTransmits or MinRcvBufs parameters in the PROTOCOL.INI file to reduce the amount of control block storage required by the device driver. Shut down and restart the computer to activate this configuration change.

LA10053E (DOS Only)

Device Driver could not initialize. Failure code: *xx*

Explanation: The device driver was not able to initialize itself. This is most often caused by conflicts between the device driver and other resources in the system.

User Action: Record this message number and the failure code and contact your support personnel for assistance.

LA10054E (DOS Only)

No adapters supported by %1 were found or adapters were not correctly configured by the machine and its BIOS.

Explanation: The device driver was not able to find any adapters that it knows about. Either the adapter is not installed in the computer, the adapter is malfunctioning, or the system BIOS has not correctly configured the adapter.

User Action: Record this message number and contact your support personnel for assistance.

LA10055E (DOS Only)

No adapters initialized correctly. *xx* adapters were found in the machine.

Explanation: The device driver was able to find the stated number of adapters. However, none of the adapters were successfully initialized. This message is often displayed along with one or more other messages from the device driver.

User Action: Record this message number as well as any other messages from the device drivers along with any specific failure codes in the messages and contact your support personnel for assistance.

Appendix E. Novell NetWare Server and LAN Client Driver Parameters

For the Novell NetWare server, the parameters are set on the command line or on the load IBMTRPO line in the AUTOEXEC.NCF file.

For the LAN Client environment, the parameters are set on the load IBMTRPO line of the STARTNET.BAT file. The length of the command cannot exceed 127 characters.

Table 8. Novell NetWare Driver Parameters

Parameter	Explanation
DATARATE=	<p>Configures the Token-Ring data rate for the adapter. It is recommended for servers that the DATARATE be set to M16 or M4, and clients be set to AUTO.</p> <p>This parameter is ignored for 100-Mbps network operation.</p> <p>Valid values:</p> <p>AUTO AutoSense – automatic ring-speed detection. Note: The adapter will not function with AutoSense if it is the first one on the ring. AutoSense is not designed for changing ring speed while the adapter is operational. It is usually necessary to reload the driver.</p> <p>M16 16-Mbps ring speed operation.</p> <p>M4 4-Mbps ring speed operation.</p> <p>The default is AUTO. Note: If using Novell NetWare SFTIII, M16 or M4 must be selected for the DATARATE parameter on both of the SFTIII machines. Do not use AUTO.</p>
FRAME=	<p>This string defines the frame type to be used with the adapter when loading the IBMTRPO LAN driver.</p> <p>Token-Ring drivers can add most-significant bit (MSB) or least-significant bit (LSB) following the frame type designation. LSB forces canonical addresses to be passed between the MLID and the upper layers. The MSB designation forces non-canonical addresses to be passed (this is the default for Token-Ring media).</p> <p>Valid values: TOKEN-RING or TOKEN-RING_SNAP</p> <p>The default is TOKEN-RING.</p>
FULLDUPLEX=	<p>This keyword permits the IBMTRPO LAN driver to activate Token-Ring full-duplex operation supported by the adapter and the NetWare server environment.</p> <p>Valid values: YES, NO</p> <p>The default is YES.</p>

Table 8. Novell NetWare Driver Parameters (continued)

Parameter	Explanation
NODE=	<p>This keyword is used to set a locally administered address for the adapter. A local address must contain 12 hexadecimal characters and can be specified in either most-significant bit (MSB) or least-significant bit (LSB) format.</p> <p>To specify an MSB node address, the letter M immediately follows the last digit of the node address. To specify an LSB node address, the letter L immediately follows the last digit of the node address. If neither an M nor L is specified after the last digit of the node address, MSB will be assumed.</p> <p>If a node address is specified in MSB format, the value must be within the range X'400000000000' to X'7FFFFFFFFFFF' (for example, X'400000000002'M). This same address specified in LSB format would be X'020000000080'L with an L optionally appended to the end.</p> <p>Notes:</p> <ol style="list-style-type: none"> 1. Do not assign the same local address to two or more stations. Severe station communication or network failures can occur when two or more stations are assigned the same address. 2. If you do not assign a locally administered address, the adapter uses the universally administered address permanently encoded in its memory.
RNICOPEN=	<p>This is a Server environment only keyword parameter. The RNICOPEN keyword permits the IBM Token-Ring PCI Family Adapter being controlled by the driver to function as a quick failover redundant adapter in conjunction with IBMRNIC.NLM. The required keyword value is used to specify the locally administered address to be used for this adapter in the redundant NIC pair. When the RNICOPEN keyword is specified, the adapter will not function until IBMRNIC.NLM is properly configured. Using this keyword causes the adapter to be controlled by IBMRNIC.NLM; it will NOT function as one would normally expect. Do NOT enable this keyword parameter without consulting the Redundant NIC chapter of the IBM Token-Ring Adapter Features document.</p> <p>Valid values:</p> <p>A locally administered address containing 12 hexadecimal characters specified in most-significant bit (MSB) format. The value must be within the range X'400000000000' to X'7FFFFFFFFFFF' (for example, X'400000000002'). Use a configuration NLM (NWCONFIG or INSTALL) to assist with the correct usage of this parameter.</p> <p>The same Failover address must be specified for both adapters in a redundant NIC pair.</p> <p>This parameter is disabled by default.</p>
RXBUFFERS=	<p>This keyword defines the number of receive buffers used by the IBMTRPO LAN driver.</p> <p>Valid values:</p> <p>4 to 64</p> <p>The default is 32. For IBM LAN Client, the default is 4.</p> <p>Note: Receive buffer size is defined by the server SET command. Refer to your Novell NetWare system administration documentation for more information.</p>
SLOT=	<p>This keyword defines the slot number of the corresponding adapter in the computer. To avoid being prompted to enter a slot number when the IBMTRPO LAN driver is loaded, specify this keyword. One SLOT number is required for each NIC if you are using more than one.</p>

Table 8. Novell NetWare Driver Parameters (continued)

Parameter	Explanation
STANDBY	<p>This is a Server environment only keyword parameter. The STANDBY keyword prohibits the Token-Ring PCI Family Adapter from opening on the ring and should only be used in conjunction with IBMRNIC.NLM. When the STANDBY keyword is specified, the adapter will not function until an IBMRNIC failover event occurs to this adapter. Enable Standby for the secondary adapter of a Redundant NIC adapter pair where both adapters are using Standard Failover mode. Do NOT enable this keyword parameter without consulting the Redundant NIC chapter of the Token-Ring Adapter Features document.</p> <p>Valid values: There are no values associated with this keyword. Use a configuration NLM (NWCONFIG or INSTALL) to assist with the correct usage of this parameter.</p> <p>This parameter is disabled by default.</p>
TXBUFFERS=	<p>This keyword defines the number of transmit buffers used by the IBMTRPO LAN driver.</p> <p>Valid values: 1 to 16</p> <p>The default is 16. Note: Maximum transmit frame size is defined by the server SET command. Refer to your Novell NetWare system administration documentation for more information.</p>
TXPRIMAX=	<p>Priority Transmit Maximum Level. This parameter permits the driver to set the maximum priority level that the adapter will accept. If any frame is queued for transmission at a priority level higher than this, it will be transmitted at this level.</p> <p>Valid values: 0-6</p> <p>The default is 6.</p>
TXPRITHRESH=	<p>Priority Transmit Threshold. This parameter permits the driver to set the threshold for priority transmits. An IBM Token-Ring PCI Family Adapter has two transmit channels. All frames with priority level 0 through this threshold will be transmitted over the low priority channel. All frames with a priority level greater than this threshold up to the maximum will be transmitted over the high priority channel.</p> <p>Valid values: 1-6</p> <p>The default is 1.</p>
RT=	<p>Route Switching Mode. This parameter indicates whether the driver should enable code that attempts to send routable traffic directly to a destination rather than through the router. This can improve the performance of these connections and reduce the workload at the router. If the value is Disable, all routable frames will be sent through the router.</p> <p>Valid values:</p> <ul style="list-style-type: none"> A Automatically determines whether to use Peer or Client mode. P Communicates with a peer destination station to establish a direct path. C Uses an MSS server to determine the direct path. D Deactivates the route switching function for this adapter. <p>The default is Disable.</p>

Table 8. Novell NetWare Driver Parameters (continued)

Parameter	Explanation
RTTS=	<p>Route Switching Table Size. This parameter specifies the number of entries allowed in the route table kept for Route Switching support. This should be set equal to or greater than the number of remote stations this station will send data to using routable IP frames. If it is set too low, some of the traffic that could be sent directly will instead be sent through the router.</p> <p>Valid values: 16-1024</p> <p>The default is 1024.</p>
RTSM=	<p>Route Switching IP Subnet Mask. This parameter contains a character string specifying the IP subnet mask for the IP subnet to which this adapter will attach. This value is entered as an IP dotted-decimal value (for example, 255.255.255.0). This is a mandatory parameter when the RTSWMode parameter is set to Auto or Peer.</p> <p>Valid values:</p> <p><i>xxx.xxx.xxx.xxx</i> A dotted-decimal IP network number (15 characters maximum).</p> <p>Disable When not in use.</p> <p>The default is Disable.</p>
RTHT=	<p>Route Switching Holding Time. This parameter specifies the Route Switching information holding time value. This determines how often a remote station must refresh its Route Switching information which pertains to this station.</p> <p>Valid values: 2 to 20</p> <p>The default is 20.</p>
TPRn=	<p>TCP Port Range. This represents a set of parameters which designate the transmit frame priority value for a specified TCP port range. n is 1, 2, 3, 4, or 5. The format of this 9-digit hexadecimal string is:</p> <p>PortNumber PortNumber PriorityValue</p> <p>where each PortNumber is a four-character hex value and PriorityValue is a one-character hex value. The two PortNumber fields define a starting and ending value that make up a range, with the starting value less than or equal to the ending value.</p> <p>Valid values:</p> <p>PortNumber 0x0000 to 0xFFFF</p> <p>PriorityValue 1 to 6</p> <p>There is no default for this parameter.</p>

Table 8. Novell NetWare Driver Parameters (continued)

Parameter	Explanation
UPRn=	<p>UDP Port Range. This represents a set of parameters which designate the transmit frame priority value for a specified UDP port range. n is 1, 2, 3, 4, or 5. The format of this 9-digit hexadecimal string is:</p> <p style="padding-left: 40px;">PortNumber PortNumber PriorityValue</p> <p>where each PortNumber is a four-character hex value and PriorityValue is a one-character hex value. The two PortNumber fields define a starting and ending value that make up a range, with the starting value less than or equal to the ending value.</p> <p>Valid values:</p> <p>PortNumber 0x0000 to 0xFFFF</p> <p>PriorityValue 1 to 6</p> <p>There is no default for this parameter.</p>

Appendix F. Novell NetWare Server and LAN Client Driver Messages

IBMTRPO-xx-202:

The adapter UAA (BIA) is xxx.

Explanation: Information only.

User Action: None.

IBMTRPO-xx-203:

The adapter is using an LAA of xxx.

Explanation: Information only.

User Action: None.

IBMTRPO-xx-204:

Revision level xxx of the adapter is incompatible with this driver version.

Explanation: The Revision ID of the adapter is not one that is supported by this version of the device driver. This correlation is enforced to ensure an appropriate match between the hardware and the device driver software.

User Action: Contact your customer service center for assistance. You might need to upgrade your adapter, use a different version of the device driver, or both.

IBMTRPO-xx-205:

A device driver initialization error occurred (failure code xxx).

Explanation: An unexpected error occurred during initialization of the device driver.

User Action: Shut down the computer and switch OFF the power to the machine. Restart the computer by switching it ON again. If the error persists, contact your customer service center.

IBMTRPO-xx-206:

The configuration parameter xxx was specified incorrectly. Its default value will be used.

Explanation: The value of a configuration parameter was incorrectly specified.

User Action: Edit the configuration file (or rerun the configuration program) to specify a value that is of the correct type and within the allowed range. Check the installation instructions for additional information.

IBMTRPO-xx-207:

The configuration parameter values have forced the internal data blocks to exceed the allowed limit.

Explanation: The combination of configuration parameters being used requires more than the 64-KB memory area that is available for this adapter instance to hold its internal control information.

User Action: Lower the value of the TXBUFFERS or RXBUFFERS parameters from their current setting to reduce the amount of control-block storage required by the device driver. Unload and reload IBMTRPO to activate this configuration change.

IBMTRPO-xx-208:

Unable to register interrupt level xxx for this adapter.

Explanation: The hardware interrupt level assigned to this adapter was not able to be registered (*hooked*) by the device driver.

User Action: Check the configuration of your computer, looking for other devices that are assigned the same interrupt level as this adapter. Try removing the conflicting device from the machine and resting the computer to see if the problem is resolved. If so, determine whether the conflicting device can be left out of the machine, or whether the

machine can be reconfigured to resolve the conflict. Note that in most PCI machines, the PCI BIOS assigns certain system resources to the devices found in the computer, including the interrupt level.

IBMTRPO-xx-210:

A hardware failure occurred while attempting to open the adapter.

Explanation: A hardware error was detected when opening the adapter for network operation.

User Action: Run the diagnostics program. See "Adapter Diagnostics" on page 42.

IBMTRPO-xx-211:

A possible lobe wire failure was detected while attempting to insert into the network.

Explanation: The adapter is not correctly connected to the Token-Ring network.

User Action: Check that the cable is securely attached to both the adapter and to the Token-Ring network. You might need to contact your local network administrator to ensure that the cabling in the building is intact and that the network concentrator to which you are attached is operational. If the error persists, try using a different cable.

IBMTRPO-xx-212:

A signal loss condition was detected while attempting to insert into the network.

Explanation: The Token-Ring network is not functioning correctly.

User Action: Contact your local network administrator to determine the status of your network, or try connecting again at a later time.

IBMTRPO-xx-213:

The lobe wire connected to the adapter is not attached to the network.

Explanation: The adapter is not correctly connected to the Token-Ring network.

User Action: Check that the cable is securely attached to both the adapter and to the Token-Ring network. You may need to contact your local network administrator to ensure that the cabling in the building is intact and that the network concentrator to which you are attached is operational. If the error persists, try using a different cable.

IBMTRPO-xx-214:

The configured data rate for the adapter does not match that of the network.

Explanation: The operational speed of the Token-Ring network does not match the configured speed of the adapter.

User Action: Change the setting of the DATARATE configuration parameter to match the speed of the network to which the adapter is attached. Your local network administrator should be able to tell you which speed to use. Setting the DataRate parameter value to AUTO will allow the adapter to automatically determine the correct speed setting to use when connecting to the network, provided that this is not the only adapter active on the Token Ring. Consult the adapter installation instructions for additional information on setting the DataRate parameter.

This message is relevant for 4-Mbps and 16-Mbps operation only.

IBMTRPO-xx-215:

An adapter timeout occurred while attempting to insert into the network.

Explanation: The Token-Ring network is not functioning correctly.

User Action: Contact your local network administrator to determine the status of your network, or try connecting again at a later time.

IBMTRPO-xx-216:

A ring failure condition was detected while attempting to insert into the network.

Explanation: The Token-Ring network is not functioning correctly.

User Action: Contact your local network administrator to determine the status of your network, or try connecting again at a later time.

IBMTRPO-xx-217:

A ring beaconing condition was detected while attempting to insert into the network.

Explanation: The Token-Ring network is not functioning correctly.

User Action: Contact your local network administrator to determine the status of your network, or try connecting again at a later time.

IBMTRPO-xx-218:

A duplicate network address was detected while attempting to insert into the network.

Explanation: The address specified for the NetAddress configuration parameter is being used by another adapter (ring station) on the network.

User Action: Modify the configuration file to change the Node parameter value being used for this adapter, or remove the Node parameter to allow the universally administered address to be used. Contact your local network administrator for assistance with choosing a new Node parameter value, or to have the conflicting adapter removed from the same Token-Ring network as this adapter.

IBMTRPO-xx-219:

A ring parameter failure occurred while attempting to insert into the network.

Explanation: The Token-Ring network is not functioning correctly.

User Action: Contact your local network administrator to determine the status of your network, or try connecting again at a later time.

IBMTRPO-xx-220:

The adapter was forced to remove itself while attempting to insert into the network.

Explanation: The Token-Ring network rejected the attempt by this adapter to connect to it.

User Action: Contact your local network administrator to determine the status of your network, or try connecting again at a later time.

IBMTRPO-xx-221:

A hardware failure occurred while attempting to open the adapter.

Explanation: A hardware error was detected when opening the adapter for network operation.

User Action: Run the diagnostics program. See "Adapter Diagnostics" on page 42.

IBMTRPO-xx-222:

A hardware failure occurred while attempting to open the adapter.

Explanation: A hardware error was detected when opening the adapter for network operation.

User Action: Run the diagnostics program. See "Adapter Diagnostics" on page 42.

IBMTRPO-xx-223:

The adapter cannot be opened in AutoSense mode if it is the only active station on the network.

Explanation: The DataRate configuration parameter is set to AUTO (which is also the default value if the parameter is not specified), but the adapter is the first station to open on the Token-Ring network.

User Action: This adapter is designed to not open onto the attached Token-Ring network if it is configured to use AutoSense detection and if it would have been the first active ring station.

The possible remedies are to try connecting again at a later time when at least one other ring station is active on the network (such as a network server), or to change the configuration value so that the DATARATE parameter is set to a specific ring-speed value of M16 or M4 and unload and load IBMTRPO to activate this configuration change.

Note that setting a specific value of M16 or M4 for the DataRate parameter will cause this adapter to establish the operational speed of the Token-Ring network if it is still the first active ring station, so consult with your local network administrator if necessary.

Check the installation instructions for additional information on setting the DataRate parameter.

This message is relevant for 4-Mbps and 16-Mbps operation only.

IBMTRPO-xx-225:

A network protocol error occurred while attempting to operate the adapter in full-duplex mode.

Explanation: The adapter was unable to successfully communicate with a Token-Ring switch when attempting to open for full-duplex operation.

User Action: Check that your full-duplex switch is functioning correctly and that the adapter is correctly connected to it. If this problem persists, contact your customer service center.

IBMTRPO-xx-226:

Unable to automatically change to xx Mbps operation. Please reboot the computer.

Explanation: The adapter attempted to open at one speed, but found the Token Ring operating at another speed. The configuration parameters used during initialization processing, notably the maximum frame size, preclude reliable operation at the new speed, so all additional attempts to open the adapter will be rejected. Rebooting the computer allows the new speed to be factored into the initialization processing without requiring a configuration change in most cases.

User Action: Shutdown and restart the computer. Normally, no explicit configuration changes are required to begin operating at the current operational speed of the Token Ring. Optionally, you might be able to change the value of the configuration parameter that specifies the maximum frame size to a value of 4500 or less to eliminate needing to reboot the computer for a similar situation in the future.

IBMTRPO-xx-227:

The adapter opened for Token Ring, xxx Mbps, half duplex.

Explanation: Information only.

User Action: None.

IBMTRPO-xx-228:

The adapter opened for Token Ring, xxx Mbps, full-duplex.

Explanation: Information only.

User Action: None.

IBMTRPO-xx-233:

Adapter analysis code is xxx.

Explanation: Information only.

User Action: None.

IBMTRPO-xx-234:

Adapter full-duplex operation has now been activated.

Explanation: Information only.

User Action: None.

IBMTRPO-xx-304:

Adapter is disconnected from the media.

Explanation: The media network is not functioning correctly.

User Action: Verify that the cable is securely attached to both the adapter and the Token-Ring network. Run diagnostics if the problem persists. You might need to contact your local administrator to ensure that the cabling in the building is intact and that the network concentrator to which you are attached is operational. If the error persists, try using a different cable.

IBMTRPO-xx-305:

Condition restored. The adapter is connected to the media.

Explanation: Information only.

User Action: None.

Appendix G. Novell NetWare DOS ODI Driver Parameters

The following parameters can be configured in the NET.CFG file.

Table 9. DOS and OS/2 Configurable Driver Parameters in the NET.CFG file.

Parameter	Explanation
FRAME	<p>This keyword defines the frame type used with the adapter.</p> <p>Valid values:</p> <ul style="list-style-type: none">• TOKEN-RING MSB• TOKEN-RING LSB• TOKEN-RING_SNAP MSB• TOKEN-RING_SNAP LSB <p>The default value is Token-Ring MSB.</p>
NODE ADDRESS	<p>To set a locally administered address for the adapter, type the local address you want to use. The local address must contain 12 hexadecimal characters and can be specified in either most-significant bit (MSB), which is the default, or least-significant bit (LSB) format. To specify an MSB node address, the letter "M" immediately follows the last digit of the node address. To specify an LSB node address, the letter "L" immediately follows the last digit of the node address.</p> <p>If a node address is specified in MSB format, the characters must be within the range X'400000000000'–X'7FFFFFFFFF'. To specify a node address in MSB format, append an "M" to the end of the address (for example, 400000000001M). This address specified in LSB format would be X'020000000080L'.</p> <p>Notes:</p> <ol style="list-style-type: none">1. Do not assign the same local address to two or more stations. Severe station communication or network failures may occur when two or more stations are assigned the same address.2. If you do not assign a locally administered address, the adapter uses the universally administered address (the address encoded in the adapter memory at the factory). The universally administered address appears on a label on the adapter. See Figure 4 on page 40 for an illustration.
SLOT	<p>This keyword defines the slot number of the corresponding adapter in the computer. Slots must be assigned sequentially. This assignment is used to avoid conflict with other adapters.</p> <p>Valid values: 10001 or 10002</p> <p>The default value is 10001.</p>
DATARATE	<p>This keyword defines the data-rate setting for the adapter. It is recommended that clients be set to AUTO.</p> <p>This keyword is ignored for 100-Mbps network operation.</p> <p>Valid values:</p> <p>AUTO AutoSense – automatic ring-speed detection. Note: The adapter will not function with AutoSense if the adapter is the first one on the ring. AutoSense is not designed for changing ring speed while the adapter is operational. It is usually necessary to reload the driver.</p> <p>M16 16-Mbps ring-speed operation.</p> <p>M4 4-Mbps ring-speed operation.</p> <p>The default value is AUTO.</p>

Table 9. DOS and OS/2 Configurable Driver Parameters in the NET.CFG file. (continued)

Parameter	Explanation
RXBUFFERS	<p>This keyword defines the number of receive buffers used by the driver.</p> <p>Valid values: 9 to 64</p> <p>The default value is 16.</p>
TXBUFFERS	<p>This keyword defines the number of transmit buffers used by the driver.</p> <p>Valid values: 1 to 3</p> <p>The default value is 1.</p>
FULLDUPLEX	<p>This keyword influences whether a full-duplex network connection will be requested by the adapter.</p> <p>Valid values: NO, YES</p> <p>The default value is YES.</p>

Appendix H. Notices

This information was developed for products and services offered in the U.S.A.

IBM may not offer the products, services, or features discussed in this document in other countries. Consult your local IBM representative for information on the products and services currently available in your area. Any reference to an IBM product, program, or service is not intended to state or imply that only that IBM product, program, or service may be used. Any functionally equivalent product, program, or service that does not infringe any IBM intellectual property right may be used instead. However, it is the user's responsibility to evaluate and verify the operation of any non-IBM product, program, or service.

IBM may have patents or pending patent applications covering the subject matter in this document. The furnishing of this document does not give you any license to these patents. You can send license inquiries, in writing, to:

IBM Director of Licensing
IBM Corporation
North Castle Drive
Armonk, NY 10504-1785
U.S.A.

For license inquiries regarding double-byte (DBCS) information, contact the IBM Intellectual Property Department in your country or send inquiries, in writing, to:

IBM World Trade Asia Corporation
Licensing
2-31 Roppongi 3-chome, Minato-ku
Tokyo 106, Japan

The following paragraph does not apply to the United Kingdom or any other country where such provisions are inconsistent with local law: INTERNATIONAL BUSINESS MACHINES CORPORATION PROVIDES THIS PUBLICATION "AS IS" WITHOUT WARRANTY OF ANY KIND, EITHER EXPRESS OR IMPLIED, INCLUDING, BUT NOT LIMITED TO, THE IMPLIED WARRANTIES OF NON-INFRINGEMENT, MERCHANTABILITY, OR FITNESS FOR A PARTICULAR PURPOSE. Some states do not allow disclaimer of express or implied warranties in certain transactions, therefore, this statement may not apply to you.

This information could include technical inaccuracies or typographical errors. Changes are periodically made to the information herein; these changes will be incorporated in new editions of the publication. IBM may make improvements and/or changes in the product(s) and/or program(s) described in this publication at any time without notice.

Any references in this information to non-IBM Web sites are provided for convenience only and do not in any manner serve as an endorsement of those Web sites. The materials at those Web sites are not part of the materials for this IBM product and use of those Web sites is at your own risk.

Information concerning non-IBM products was obtained from the suppliers of those products, their published announcements or other publicly available sources. IBM has not tested those products and cannot confirm the accuracy of performance, compatibility or any other claims related to non-IBM products. Questions on the capabilities of non-IBM products should be addressed to the suppliers of those products.

This information is for planning purposes only. The information herein is subject to change before the products described become available.

Trademarks

The following terms are trademarks of the IBM Corporation in the United States or other countries or both:

IBM
Alert on LAN
AIX
HelpCenter
Nways
Operating System/2
OS/2
Wake on LAN

Microsoft, Windows, and Windows NT, and theWindows logo are trademarks of Microsoft Corporation in the United States, other countries, or both.

LANDesk is a trademark of Intel Corporation in the United States, other countries, or both.

Other company, product and service names may be trademarks or service marks of others.

Notice to Users of Online Versions of This Book

For online versions of this book, you are authorized to:

- Copy, modify, and print the documentation contained on the media, for use within your enterprise, provided you reproduce the copyright notice, all warning statements, and other required statements on each copy or partial copy.
- Transfer the original unaltered copy of the documentation when you transfer the related IBM product (which may be either machines you own, or programs, if the program's license terms permit a transfer). You must, at the same time, destroy all other copies of the documentation.

You are responsible for payment of any taxes, including personal property taxes, resulting from this authorization.

THERE ARE NO WARRANTIES, EXPRESS OR IMPLIED, INCLUDING THE WARRANTIES OF MERCHANTABILITY AND FITNESS FOR A PARTICULAR PURPOSE.

Some jurisdictions do not allow the exclusion of implied warranties, so the above exclusion may not apply to you.

Your failure to comply with the terms above terminates this authorization. Upon termination, you must destroy your machine-readable documentation.

Electronic Emission Notices

IBM High-Speed 100/16/4 Token-Ring PCI Adapter (P/N 34L0501, 34L0510)
IBM 16/4 Token-Ring PCI Adapter 2 (P/N 34L0601, 34L0610)

**IBM 16/4 Token-Ring PCI Special (P/N 01L1507)
IBM 16/4 Token-Ring PCI Adapter 2 with Wake on LAN (P/N 34L0701, 34L0710)
when using Shielded Twisted Pair Cable Media or when using
Unshielded Twisted Pair Cable and a Shielded Power Cord**

Federal Communications Commission (FCC) Statement

Note: This equipment has been tested and found to comply with the limits for a Class B digital device, pursuant to Part 15 of the FCC Rules. These limits are designed to provide reasonable protection against harmful interference in a residential installation. This equipment generates, uses, and can radiate radio frequency energy and, if not installed and used in accordance with the instructions, may cause harmful interference to radio communications. However, there is no guarantee that interference will not occur in a particular installation. If this equipment does cause harmful interference to radio or television reception, which can be determined by turning the equipment off and on, the user is encouraged to try to correct the interference by one or more of the following measures:

- Reorient or relocate the receiving antenna.
- Increase the separation between the equipment and receiver.
- Connect the equipment into an outlet on a circuit different from that to which the receiver is connected.
- Consult an IBM authorized dealer or service representative for help.

Properly shielded and grounded cables and connectors must be used in order to meet FCC emission limits. Proper cables and connectors are available from IBM authorized dealers. IBM is not responsible for any radio or television interference caused by using other than recommended cables and connectors or by unauthorized changes or modifications to this equipment. Unauthorized changes or modifications could void the user's authority to operate the equipment.

This device complies with Part 15 of the FCC Rules. Operation is subject to the following two conditions: (1) this device may not cause harmful interference, and (2) this device must accept any interference received, including interference that may cause undesired operation.

Responsible Party:

International Business Machines Corporation
Old Orchard Road
Armonk, NY 10504
Telephone 1-919-543-2193

Other Electronic Emission Notices for STP Media

Industry Canada Class B Emission Compliance Statement

This Class B digital apparatus meets the requirements of the Canadian Interference-Causing Equipment Regulations.

Avis de conformité aux normes d'Industrie Canada

Cet appareil numérique de la classe B respecte toutes les exigences du Règlement sur le matériel brouilleur du Canada.

European Norm (EN) Statement

This product is in conformity with the protection requirements of EC Council Directive 89/336/EEC on the approximation of the laws of the Member States relating to electromagnetic compatibility.

IBM cannot accept responsibility for any failure to satisfy the protection requirements resulting from a non-recommended modification of the product, including the fitting of non-IBM option cards.

Properly shielded and grounded cables and connectors must be used in order to reduce the potential for causing interference to radio and TV communications and to other electrical or electronic equipment. IBM cannot accept responsibility for any interference caused by using other than recommended cables and connectors.

Hinweis zur Elektromagnetischen Verträglichkeit (EMVG)

Dieses Gerät ist berechtigt in Übereinstimmung mit dem deutschen EMVG vom 9.Nov.92 das EG-Konformitätszeichen zu führen.

Der Aussteller der Konformitätserklärung ist die

IBM UK Ltd
PO Box 30
Spango Valley,
Greenock,
Scotland PA16 0AH.

Dieses Gerät erfüllt die Bedingungen der EN 55022 Klasse B.

Japanese Voluntary Control Council for Interference (VCCI) Statement

This product is a Class B Information Technology Equipment and conforms to the standards set by the Voluntary Control Council for Interference by Technology Equipment (VCCI). This product is aimed to be used in a domestic environment. When used near a radio or TV receiver, it may become the cause of radio interference. Read the instructions for correct handling.

この装置は、情報処理装置等電波障害自主規制協議会（VCCI）の基準に基づきクラスB情報技術装置です。この装置は、家庭環境で使用することを目的としていますが、この装置がラジオやテレビジョン受信機に近接して使用されると、受信障害を引き起こすことがあります。
取扱説明書に従って正しい取り扱いをして下さい。

Other Electronic Emission Notices for UTP Media

In order to be compliant with FCC Class B, EN55022 Class B, and VCCI Class B emissions standards, as stated in “Other Electronic Emission Notices for STP Media” on page 79 when using this adapter with UTP cabling, you MUST use a shielded power cord as described in “Power Cord Notices for UTP Media” on page 82 to attach your PC to the AC outlet. Otherwise, the following statements apply for this adapter.

Federal Communications Commission (FCC) Statement

Note: This equipment has been tested and found to comply with the limits for a Class A digital device, pursuant to Part 15 of the FCC Rules. These limits are designed to provide reasonable protection against harmful interference when the equipment is operated in a commercial environment. This equipment generates, uses, and can radiate radio frequency energy and, if not installed and used in accordance with the instruction manual, may cause harmful interference to radio communications. Operation of this equipment in a residential area is likely to cause harmful interference, in which case the user will be required to correct the interference at his own expense.

Properly shielded and grounded cables and connectors must be used in order to meet FCC emission limits. IBM is not responsible for any radio or television interference caused by using other than recommended cables and connectors or by unauthorized changes or modifications to this equipment. Unauthorized changes or modifications could void the user's authority to operate the equipment.

This device complies with Part 15 of the FCC Rules. Operation is subject to the following two conditions: (1) this device may not cause harmful interference, and (2) this device must accept any interference received, including interference that may cause undesired operation.

Industry Canada Class A Emission Compliance Statement

This Class A digital apparatus meets the requirements of the Canadian Interference-Causing Equipment Regulations.

Avis de conformité aux normes d'Industrie Canada

Cet appareil numérique de la classe A respecte toutes les exigences du Règlement sur le matériel brouilleur du Canada.

European Norm (EN) Statement

This product is in conformity with the protection requirements of EC Council Directive 89/336/EEC on the approximation of the laws of the Member States relating to electromagnetic compatibility.

IBM cannot accept responsibility for any failure to satisfy the protection requirements resulting from a non-recommended modification of the product, including the fitting of non-IBM option cards.

Warning: This is a Class A product. In a domestic environment this product may cause radio interference in which case the user may be required to take adequate measures.

Operation of this product in a domestic/residential environment may cause radio interference, which the user may be required to take measures to suppress.

Zulassungsbescheinigung laut dem Deutschen Gesetz über die elektromagnetische Verträglichkeit von Geräten (EMVG) vom 30. August 1995 (bzw. der EMC EG Richtlinie 89/336).

Dieses Gerät ist berechtigt in Übereinstimmung mit dem Deutschen EMVG das EG-Konformitätszeichen - CE - zu führen.

Verantwortlich für die Konformitätserklärung nach Paragraph 5 des EMVG ist die IBM Deutschland Informationssysteme GmbH, 70548 Stuttgart.

Informationen in Hinsicht EMVG Paragraph 3 Abs. (2) 2:

Das Gerät erfüllt die Schutzanforderungen nach EN 50082-1 und EN 55022 Klasse A.
--

EN 55022 Klasse A Geräte müssen mit folgendem Warnhinweis versehen werden: "Warnung: dies ist eine Einrichtung der Klasse A. Diese Einrichtung kann im Wohnbereich Funkstörungen verursachen; in diesem Fall kann vom Betreiber verlangt werden, angemessene Maßnahmen durchzuführen und dafür aufzukommen."

EN 50082-1 Hinweis: "Wird dieses Gerät in einer industriellen Umgebung betrieben (wie in EN 50082-2 festgelegt), dann kann es dabei eventuell gestört werden. In solch einem Fall ist der Abstand bzw. die Abschirmung zu der industriellen Störquelle zu vergrößern."

Anmerkung: Um die Einhaltung des EMVG sicherzustellen sind die Geräte, wie in den IBM Handbüchern angegeben, zu installieren und zu betreiben.

Japanese Voluntary Control Council for Interference (VCCI) Statement

This is a Class A product based on the standard of the Voluntary Control Council for Interference by Information Technology Equipment (VCCI). If this equipment is used in a domestic environment, radio disturbance may arise. When such trouble occurs, the user may be required to take corrective actions.

この装置は、情報処理装置等電波障害自主規制協議会（VCCI）の基準に基づきクラスA情報技術装置です。この装置を家庭環境で使用すると電波妨害を引き起こすことがあります。この場合には使用者が適切な対策を講ずるよう要求されることがあります。

Power Cord Notices for UTP Media

When using the adapter in a Class B environment with UTP cable media, you must use a shielded power cord to attach your PC to the AC outlet in order to be Class B compliant.

Shielded power cords used in the United States and Canada are listed by Underwriters Laboratories (UL) and certified by the Canadian Standards Association (CSA). Always purchase a shielded power cord with the UL or CSA rating located on the packaging or power cord itself. These shielded power cords are readily available at your local electronic distributors. IBM makes the shielded power cord P/N 6952304 available through your IBM Marketing Representative for use at 115 volts in the United States and Canada. If purchasing other than the IBM P/N, use a UL-listed or CSA-certified shielded power cord consisting of a minimum 18 AWG, type SVT or SJT, three-conductor line cord, a maximum of 15 feet in length, and a NEMA WD-1 5-15P type attachment plug rated at 15 amperes, 125 volts.

For PCs intended to be operated at 230 volts in the United States and Canada, use IBM shielded line cord P/N 1838578, available through your IBM Marketing Representative or purchase a UL-listed or CSA-certified line cord consisting of a

minimum 18 AWG, type SVT or SJT, three-conductor cord, a maximum of 15 feet in length, and a NEMA WD-1 6-15P type attachment plug rated at 15 amperes, 250 volts.

For all PCs intended to be operated at 230 volts outside the United States and Canada, use the shielded line cord specific to your country as shown in the following table. These shielded power cords are available through your country IBM Marketing Representative.

Table 10. Power Cords Listed by Country

IBM Power Cord Part Number	Used in These Countries
13F9948	Argentina, Australia, China (PRC), New Zealand, Papua New Guinea, Paraguay, Uruguay, Western Samoa
13F9988	Afghanistan, Algeria, Andorra, Angola, Austria, Belgium, Benin, Bulgaria, Burkina Faso, Burundi, Cameroon, Central African Rep., Chad, Czech Republic, Egypt, Finland, France, French Guiana, Germany, Greece, Guinea, Hungary, Iceland, Indonesia, Iran, Ivory Coast, Jordan, Lebanon, Luxembourg, Macau, Malagasy, Mali, Martinique, Mauritania, Mauritius, Monaco, Morocco, Mozambique, Netherlands, New Caledonia, Niger, Norway, Poland, Portugal, Romania, Senegal, Slovakia, Spain, Sudan, Sweden, Syria, Togo, Tunisia, Turkey, former USSR, Vietnam, former Yugoslavia, Zaire, Zimbabwe
14F0006	Denmark
14F0024	Bangladesh, Burma, Pakistan, South Africa, Sri Lanka
14F0042	Antigua, Bahrain, Brunei, Channel Islands, Cyprus, Dubai, Fiji, Ghana, Hong Kong, India, Iraq, Ireland, Kenya, Kuwait, Malawi, Malaysia, Malta, Nepal, Nigeria, Polynesia, Qatar, Sierra Leone, Singapore, Tanzania, Uganda, United Kingdom, Yemen, Zambia
14F0060	Liechtenstein, Switzerland
14F0078	Chile, Ethiopia, Italy, Libya, Somalia
14F0096	Israel
1838578	Thailand
6952304 (115v usage) 1838579 (230v usage)	Bahamas, Barbados, Bermuda, Bolivia, Brazil, Canada, Cayman Islands, Colombia, Costa Rica, Dominican Republic, Ecuador, El Salvador, Guatemala, Guyana, Haiti, Honduras, Jamaica, Japan, Korea (South), Liberia, Mexico, Netherlands Antilles, Nicaragua, Panama, Peru, Philippines, Saudi Arabia, Suriname, Taiwan, Trinidad (West Indies), United States of America, Venezuela

IBM License Agreement for Productivity Aids

IF YOU DOWNLOAD OR USE THIS PROGRAM YOU AGREE TO THESE TERMS.

International Business Machines Corporation grants you a license to use the Program only in the country where you acquired it and only for use with IBM Networking Products (IBM networking interface cards made Generally Available by IBM). The Program is copyrighted and licensed (not sold). We do not transfer title to the Program to you. You obtain no rights other than those granted you under this license.

Under this license, you may:

1. use the Program on one or more machines at a time;
2. make copies of the Program for use or backup purposes within your Enterprise;

3. modify the Program and merge it into another program; and make copies of the original file you downloaded and distribute it, provided that you transfer a copy of this license to the other party. The other party agrees to these terms by its first use of the Program.

You must reproduce the copyright notice and any other legend of ownership on each copy or partial copy, of the Program.

You may NOT:

1. distribute the Program over electronic networks (except internally), or by means of electronic "bulletin boards".
2. sublicense, rent, lease, or assign the Program.
3. reverse assemble, reverse compile, or otherwise translate the Program.

We do not warrant that the Program is free from claims by a third party of copyright, patent, trademark, trade secret, or any other intellectual property infringement.

Under no circumstances are we liable for any of the following:

1. third-party claims against you for losses or damages;
2. loss of, or damage to, your records or data;
3. economic consequential damages (including lost profits or savings) or incidental damages, even if we are informed of their possibility.

Some jurisdictions do not allow these limitations or exclusions, so they may not apply to you.

We do not warrant uninterrupted or error free operation of the Program. We have no obligation to provide service, defect correction, or any maintenance for the Program. We have no obligation to supply any Program updates or enhancements to you even if such are or later become available.

IF YOU DOWNLOAD OR USE THIS PROGRAM YOU AGREE TO THESE TERMS.

THERE ARE NO WARRANTIES, EXPRESS OR IMPLIED, INCLUDING THE IMPLIED WARRANTIES OF MERCHANTABILITY AND FITNESS FOR A PARTICULAR PURPOSE.

Some jurisdictions do not allow the exclusion of implied warranties, so the above exclusion may not apply to you.

You may terminate this license at any time. We may terminate this license if you fail to comply with any of its terms. In either event, you must destroy all your copies of the Program.

You are responsible for the payment of any taxes resulting from this license.

You may not sell, transfer, assign, or subcontract any of your rights or obligations under this license. Any attempt to do so is void.

Neither of us may bring a legal action more than two years after the cause of action arose.

If you acquired the Program in the United States, this license is governed by the laws of the State of New York. If you acquired the Program in Canada, this license is governed by the laws of the Province of Ontario. Otherwise, this license is governed by the laws of the country in which you acquired the Program.

NetWare Network Computing Products from IBM

The following additional license terms apply to the Novell IntranetWare Client for DOS and Windows 3.1 code, included with IBM's LAN Client program. In the event of any inconsistency between the following terms and the terms of the IBM License Agreement for Productivity Aids, the following terms shall prevail.

IF YOU DOWNLOAD OR USE THIS PROGRAM YOU AGREE TO THESE TERMS.

The IBM program you have licensed may be designed to run in a single computer system only, or it may contain modules designed to run in multiple computer system environments. The type of environment that applies is limited by the definitions that follow:

SINGLE USER PROGRAM means a program which operates on an intelligent single-user device by which the device acts as a standalone system or a peer system on a Communications Network

COMMUNICATIONS NETWORK means a computer system which allows a number of independent computing devices to communicate with each other

NETWORK HOST OR NETWORK SERVER means a single machine on which a Host program or NLM or VAP operates to provide the host or server resources to the other machines in a network

HOST PROGRAM means that portion of the NetWare network operating system that executes on the Network Host or Network Server

CLIENT PROGRAM means that portion of the NetWare network operating system that executes on the personal workstation

NLM PROGRAM OR VAP PROGRAM means an application program that executes under control of the NetWare network operating system on the Network Host or Network Server

DOCUMENTATION means the manual(s) and other printed material packaged by IBM with the Program

If you have licensed a Host Program, an NLM Program or a VAP Program, and/or Client Program, you are authorized to 1) use one copy of the Host Program on a single Network Host or Network Server; 2) use a single copy of an NLM Program or a VAP Program on a single Network Host or Network Server; and 3) use the Client Program, and to, without additional charge, reproduce and use copies, subject to the limitation identified in the Program Document- ation, of the Client Program, in support of the Host Program

Protection and Security

You must label, when recorded on portable media, Additional License Copies, Client Program Copies, copies made from them, and their documentation with the Program number, the copyright wording, and the copyright year as shown on the Program or documentation. The label of an Additional License Copy, a Client Program Copy, or a copy made from it must also include the words:

Licensed Material - Property of IBM
IBM retains title to this copy and to any copy made from it.
You may not transfer possession of this copy to any third party.

The label on documentation must also include the words:

Reprinted by permission of IBM.

Statement of Limited Warranty



International Business Machines
Corporation

Armonk, NY 10504

Statement of Limited Warranty

The warranties provided by IBM in this Statement of Limited Warranty apply only to Machines you originally purchase for your use, and not for resale, from IBM or an IBM authorized reseller. The term "Machine" means an IBM machine, its features, conversions, upgrades, elements, or accessories, or any combination of them. Machines are subject to these terms only if purchased in the United States or Puerto Rico, or Canada, and located in the country of purchase. If you have any questions, contact IBM or your reseller.

Machine IBM 16/4 Token-Ring PCI Adapter 2, IBM 16/4 Token-Ring PCI Adapter 2 with Wake on LAN, IBM High-Speed 100/16/4 Token-Ring PCI Adapter

Warranty Period* Lifetime

**Elements and accessories are warranted for three months. Contact your place of purchase for warranty service information.*

Production Status

Each Machine is manufactured from new parts, or new and serviceable used parts (which perform like new parts). In some cases, the Machine may not be new and may have been previously installed. Regardless of the Machine's production status, IBM's warranty terms apply.

The IBM Warranty

IBM warrants that each Machine 1) is free from defects in materials and workmanship and 2) conforms to IBM's Official Published Specifications. IBM calculates the expiration of the warranty period from the Machine's Date of Installation. The date on your receipt is the Date of Installation, unless IBM or your reseller informs you otherwise. During the warranty period, IBM or your reseller will provide warranty service under the type of service designated for the Machine and will manage and install engineering changes that apply to the Machine. IBM or your reseller will specify the type of service.

For a feature, conversion, or upgrade, IBM or your reseller may require that the Machine on which it is installed be 1) the designated, serial-numbered Machine and 2) at an engineering-change level compatible with the feature, conversion, or upgrade. Some of these transactions (called “Net-Priced” transactions) may include additional parts and associated replacement parts that are provided on an exchange basis. All removed parts become the property of IBM and must be returned to IBM.

Replacement parts assume the remaining warranty of the parts they replace.

If a Machine does not function as warranted during the warranty period, IBM in its sole discretion will repair, replace it (with a Machine that is at least functionally equivalent), or refund the purchase price. To obtain coverage under the warranty you may be required to present proof of purchase.

This warranty is non-transferable by the end-user customer.

Warranty Service

To obtain warranty service for the Machine, you should contact your reseller or call IBM. In the United States, call IBM at **1-800-772-2227**. In Canada, call IBM at **1-800-565-3344**. You may be required to present proof of purchase.

Depending on the Machine, the service may be 1) a “Repair” service at your location (called “On-site”) or at one of IBM’s or a reseller’s service locations (called “Carry-in”) or 2) an “Exchange” service, either On-site or Carry-in.

When a type of service involves the exchange of a Machine or part, the item IBM or your reseller replaces becomes its property and the replacement becomes yours. The replacement may not be new, but will be in good working order and at least functionally equivalent to the item replaced.

It is your responsibility to:

1. obtain authorization from the owner (for example, your lessor) to have IBM or your reseller service a Machine that you do not own;
2. where applicable, before service is provided —
 - a. follow the problem determination, problem analysis, and service request procedures that IBM or your reseller provide,
 - b. secure all programs, data, and funds contained in a Machine,
 - c. inform IBM or your reseller of changes in a Machine’s location, and
 - d. for a Machine with exchange service, remove all features, parts, options, alterations, and attachments not under warranty service. Also, the Machine must be free of any legal obligations or restrictions that prevent its exchange; and
3. be responsible for loss of, or damage to, a Machine in transit when you are responsible for the transportation charges.

Extent of Warranty

IBM does not warrant uninterrupted or error-free operation of a Machine.

Misuse, accident, modification, unsuitable physical or operating environment, improper maintenance by you, or failure caused by a product for which IBM is not responsible may void the warranties.

THESE WARRANTIES REPLACE ALL OTHER WARRANTIES, EXPRESS OR IMPLIED, INCLUDING, BUT NOT LIMITED TO, THE IMPLIED WARRANTIES OF MERCHANTABILITY AND FITNESS FOR A PARTICULAR PURPOSE. HOWEVER, SOME LAWS DO NOT ALLOW THE EXCLUSION OF IMPLIED WARRANTIES. IF THESE LAWS APPLY, THEN ALL EXPRESS AND IMPLIED WARRANTIES ARE LIMITED IN DURATION TO THE WARRANTY PERIOD. NO WARRANTIES APPLY AFTER THAT PERIOD.

In Canada, warranties include both warranties and conditions.

Some jurisdictions do not allow limitations on how long an implied warranty lasts, so the above limitation may not apply to you.

Limitation of Liability

Circumstances may arise where, because of a default on IBM's part (including fundamental breach) or other liability (including negligence and misrepresentation), you are entitled to recover damages from IBM. In each such instance, regardless of the basis on which you are entitled to claim damages, IBM is liable only for:

1. bodily injury (including death), and damage to real property and tangible personal property; and
2. the amount of any other actual loss or damage, up to the greater of \$100,000 or the charge for the Machine that is the subject of the claim.

Under no circumstances is IBM liable for any of the following:

1. third-party claims against you for losses or damages (other than those under the first item listed above);
2. loss of, or damage to, your records or data; or
3. economic consequential damages (including lost profits or savings) or incidental damages, even if IBM is informed of their possibility.

Some jurisdictions do not allow the exclusion or limitation of incidental or consequential damages, so the above limitation or exclusion may not apply to you.

This warranty gives you specific legal rights and you may also have other rights which vary from jurisdiction to jurisdiction.

Glossary of Terms and Abbreviations

This glossary defines terms and abbreviations used in this manual. It includes terms and definitions from the *IBM Dictionary of Computing* (New York; McGraw-Hill, Inc., 1994).

- The symbol (A) identifies definitions from the *American National Standard Dictionary for Information Systems*, ANSI X3.172-1990, copyright 1990 by the American National Standards Institute (ANSI). Copies can be purchased from the American National Standards Institute, 1430 Broadway, New York, New York 10018.
- The symbol (E) identifies definitions from the *ANSI/EIA Standard - 440A: Fiber Optic Terminology*, copyright 1989 by the Electronics Industries Association (EIA). Copies can be purchased from the Electronic Industries Association, 2001 Pennsylvania Avenue N.W., Washington, DC 20006.
- The symbol (I) identifies definitions from the *Information Technology Vocabulary*, developed by Subcommittee 1, Joint Technical Committee 1, of the International Organization for Standardization and the International Electrotechnical Commission (ISO/IEC JTC1/SC1).
- The symbol (T) identifies definitions from draft international standards, committee drafts, and working papers being developed by ISO/IEC JTC1/SC1.

The following cross-references are used in this glossary:

Contrast with. This refers to a term that has an opposed or substantively different meaning.

See. This refers the reader to multiple-word terms in which this term appears.

See also. This refers the reader to terms that have a related, but not synonymous, meaning.

Synonym for. This indicates that the term has the same meaning as a preferred term, which is defined in the glossary.

A

access priority. The maximum priority that a token can have for the adapter to use it for transmission.

adapter address. Twelve hexadecimal digits that identify a LAN adapter.

address. (1) In data communication, the IEEE-assigned unique code or the unique locally administered code assigned to each device or workstation connected to a network. (2) A character, group of characters, or a value that identifies a register, a particular part of storage, a data source, or a data sink. The value is represented by one or more characters. (3) To refer to a device or an item of data by its address. (4) The location in the storage of a computer where data is stored. (5) In word processing, the location, identified by the address code, of a specific section of the recording medium or storage.

APAR. Authorized program analysis report.

ARP. Address Resolution Protocol.

attach. To make a device a part of a network logically.

Note:

Not to be confused with *connect*, which implies physically connecting a device to a network.

attaching device. Any device that is physically connected to a network and can communicate over the network.

auto-removal. The removal of a device from data-passing activity without human intervention. This action is accomplished by the adapter in the device, and can be initiated by a network management program.

available memory. In a personal computer, the number of bytes of memory that can be used after memory requirements for the operating system, device drivers, and other application programs have been satisfied.

B

beaconing. An error-indicating function of token-ring adapters that assists in locating a problem causing a hard error on a token-ring network.

BIA. Burned-In Address. The address of a LAN adapter card, burned into the card and unique to the card.

BIOS. Basic Input/Output Services. See also *NetBIOS*.

block size. (1) The minimum size that frames are grouped into for retransmission. (2) The number of data elements (such as bits, bytes, characters, or records) that are recorded or transmitted as a unit.

buffer. (1) A portion of storage used to hold input or output data temporarily. (2) A routine or storage used to

compensate for a difference in data rate or time of occurrence of events, when transferring data from one device to another.

bus. (1) In a processor, a physical facility on which data is transferred to all destinations, but from which only addressed destinations may read in accordance with appropriate conventions. (2) A network configuration in which nodes are interconnected through a bidirectional transmission medium. (3) One or more conductors used for transmitting signals or power.

C

CPU. Central processing unit.

CRC. See *cyclic redundancy check (CRC)*.

CSD. corrective service diskette.

cable segment. A section of cable between components or devices on a network. A segment may consist of a single patch cable, multiple patch cables connected together, or a combination of building cable and patch cables connected together. See *LAN segment, ring segment*.

computer architecture. The organizational structure of a computer system, including hardware and software.

configuration. (1) The arrangement of a computer system or network as defined by the nature, number, and chief characteristics of its functional units. More specifically, the term may refer to a hardware configuration or a software configuration. (2) The devices and programs that make up a system, subsystem, or network. See also *system configuration*.

connect. In a LAN, to physically join a cable from a station to an access unit or network connection point. Contrast with *attach*.

control block. (1) A storage area used by a computer program to hold control information. (2) In the IBM Token-Ring Network, a specifically formatted block of information provided from the application program to the Adapter Support Interface to request an operation.

cyclic redundancy check (CRC). Synonym for *frame check sequence (FCS)*.

D

data rate. See *data transfer rate, line data rate*.

data transfer rate. The average number of bits, characters, or blocks per unit of time passing between equipment in a data-transmission session. The rate is expressed in bits, characters, or blocks per second, minute, or hour.

default. Pertaining to an attribute, value, or option that is assumed when none is explicitly specified.

default value. A value assumed when no value has been specified.

device driver. The code needed to attach and use a device on a computer or a network.

diagnostics. Modules or tests used by computer users and service personnel to diagnose hardware problems.

DLS. DOS LAN Services

DOS. See *IBM Personal Computer Disk Operating System (DOS)*.

duplex. In data communication, pertaining to a simultaneous two-way independent transmission in both directions. Synonymous with *full-duplex*. Contrast with *half-duplex*.

E

EISA. Extended Industry Standard Architecture.

enabled. (1) On a LAN, pertaining to an adapter or device that is active, operational, and able to receive frames from the network. (2) Pertaining to a state of a processing unit that allows the occurrence of certain types of interruptions. (3) Pertaining to the state in which a transmission control unit or an audio response unit can accept incoming calls on a line.

F

FCS. See *frame check sequence (FCS)*

frame. (1) The unit of transmission in some LANs, including the IBM Token-Ring Network and the IBM PC Network. It includes delimiters, control characters, information, and checking characters. On a token-ring network, a frame is created from a token when the token has data appended to it. On a token bus network (IBM PC Network), all frames including the token frame contain a preamble, start delimiter, control address, optional data and checking characters, end delimiter, and are followed by a minimum silence period. (2) A housing for machine elements. (3) In synchronous data link control (SDLC), the vehicle for every command, every response, and all information that is transmitted using SDLC procedures. Each frame begins and ends with a flag.

frame check sequence (FCS). (1) A system of error checking performed at both the sending and receiving station after a block check character has been accumulated. (2) A numeric value derived from the bits in a message that is used to check for any bit errors in transmission. (3) A redundancy check in which the check key is generated by a cyclic algorithm. Synonymous with *cyclic redundancy check (CRC)*.

FTP. File Transfer Protocol.

full-duplex. Synonym for *duplex*.

G

group address. In a LAN, a locally administered address assigned to two or more adapters to allow the adapters to copy the same frame. Contrast *locally administered address* with *universally administered address*.

H

half-duplex. In data communication, pertaining to transmission in only one direction at a time. Contrast with *duplex*.

hard error. An error condition on a network that requires that the source of the error be removed or that the network be reconfigured before the network can resume reliable operation. See also *beaconing*. Contrast with *soft error*.

I

IBM Personal Computer Disk Operating System (DOS). A disk operating system based on MS-DOS.

IDE. Integrated drive electronics.

IEEE. Institute of Electrical and Electronics Engineers.

IEEE 802.2. Data Link protocol standard for use with IEEE 802.3 (Ethernet), 802.4 (Token Bus), and 802.5 (Token Ring) standards.

initialize. In a LAN, to prepare the adapter (and adapter support code, if used) for use by an application program.

insert. To make an attaching device an active part of a LAN.

interrupt. (1) A suspension of a process, such as execution of a computer program, caused by an external event and performed in such a way that the process can be resumed. (2) To stop a process in such a way that it can be resumed. (3) In data communication, to take an action at a receiving station that causes the sending station to end a transmission. (4) A means of passing processing control from one software or microcode module or routine to another, or of requesting a particular software, microcode, or hardware function.

interrupt level. The means of identifying the source of an interrupt, the function requested by an interrupt, or the code or feature that provides a function or service.

I/O. Input/output.

IP. Internet Protocol.

IPX. (1) Internet Packet Exchange. (2) Internetwork Packet Exchange.

ISA. Industry Standard Architecture.

K

KB. (1) For processor storage and real and virtual memory, 1024 bytes. (2) For disk storage capacity and transmission rates, 1000 bytes.

L

LAN. See *local area network (LAN)*.

LANAID. LAN Adapter Installation and Diagnostic program. A LAN adapter installation and configuration program used in environments that do not support Plug and Play.

LAN Client. IBM LAN adapter environment that minimizes the amount of DOS conventional memory (below 1 MB) used by drivers and protocol stacks.

LAN segment. (1) Any portion of a LAN (for example, a single bus or ring) that can operate independently but is connected to other parts of the establishment network via bridges. (2) An entire ring or bus network without bridges. See *cable segment*, *ring segment*.

LAPS. LAN Adapter and Protocol Support.

LED. Light-emitting diode.

line data rate. The rate of data transmission over a telecommunications link.

link. (1) The logical connection between nodes including the end-to-end link control procedures. (2) The combination of physical media, protocols, and programming that connects devices on a network. (3) In computer programming, the part of a program, in some cases a single instruction or an address, that passes control and parameters between separate portions of the computer program. (4) To interconnect items of data or portions of one or more computer programs. (5) In SNA, the combination of the link connection and link stations joining network nodes.

LLC. Logical link control.

local area network (LAN). A computer network located on a user's premises within a limited geographical area. **Note:** Communication within a local area network is not subject to external regulations; however, communication across the LAN boundary may be subject to some form of regulation.

locally administered address. An adapter address that the user can assign to override the universally administered address. Contrast with *universally administered address*.

LSB. Least significant bit.

LSL. Link support layer.

M

Mbps. Megabits per second.

MBps. Megabytes per second.

medium. A physical carrier of electrical or optical energy.

media access control (MAC) protocol. In a local area network, the part of the protocol that governs communication on the transmission medium without concern for the physical characteristics of the medium, but taking into account the topological aspects of the network, in order to enable the exchange of data between data stations.

MHz. Megahertz.

MPTS. Multiple Protocol Transport Services.

MSB. Most significant bit.

N

NDIS. Network driver interface specification.

NetBIOS. Network Basic Input/Output System. An operating system interface for application programs used on IBM personal computers that are attached to the IBM Token-Ring Network. See also *BIOS*.

NLM. NetWare loadable module.

network administrator. A person who manages the use and maintenance of a network.

network architecture. The logical structure and operating principles of a computer network. See also *systems network architecture (SNA)* and *Open Systems Interconnection (OSI) architecture*.

Note:

The operating principles of a network include those of services, functions, and protocols.

node. (1) Any device, attached to a network, that transmits and/or receives data. (2) An endpoint of a link, or a junction common to two or more links in a network. (3) In a network, a point where one or more functional units interconnect transmission lines.

node address. The address of an adapter on a LAN.

O

OEM. Original equipment manufacturer.

open. (1) To make an adapter ready for use. (2) A break in an electrical circuit. (3) To make a file ready for use.

Open Systems Interconnection (OSI). (1) The interconnection of open systems in accordance with specific ISO standards. (2) The use of standardized procedures to enable the interconnection of data processing systems.

Note:

OSI architecture establishes a framework for coordinating the development of current and future standards for the interconnection of computer systems. Network functions are divided into seven layers. Each layer represents a group of related data processing and communication functions that can be carried out in a standard way to support different applications.

Open Systems Interconnection (OSI) architecture.

Network architecture that adheres to a particular set of ISO standards that relates to Open Systems Interconnection.

Open Systems Interconnection (OSI) reference

model. A model that represents the hierarchical arrangement of the seven layers described by the Open Systems Interconnection architecture.

option. (1) A specification in a statement, a selection from a menu, or a setting of a switch, that may be used to influence the execution of a program. (2) A hardware or software function that may be selected or enabled as part of a configuration process. (3) A piece of hardware (such as a network adapter) that can be installed in a device to modify or enhance device function.

P

packet. (1) In data communication, a sequence of binary digits, including data and control signals, that is transmitted and switched as a composite whole. (2) Synonymous with *data frame*. Contrast with *frame*.

parameter. (1) A variable that is given a constant value for a specified application and that may denote the application. (2) An item in a menu or for which the user specifies a value or for which the system provides a value when the menu is interpreted. (3) Data passed between programs or procedures.

path. (1) In a network, any route between any two nodes. (2) The route traversed by the information exchanged between two attaching devices in a network. (3) A command in IBM Personal Computer Disk Operating System (PC DOS) and IBM Operating System/2[®] (OS/2) that specifies directories to be searched for commands or batch files that are not found by a search of the current directory.

PC. Personal computer.

PCI. Peripheral Component Interconnect.

Peripheral Component Interconnect (PCI). The PCI Local Bus is a high performance 32-bit or 64-bit bus. It is intended for use as an interconnect mechanism between highly integrated peripheral controller components, peripheral add-in boards, and processor/memory systems.

power-on self-test (POST). A series of diagnostic tests that are run automatically each time the computer's power is turned on.

protocol. (1) A set of semantic and syntactic rules that determines the behavior of functional units in achieving communication. (2) In SNA, the meanings of and the sequencing rules for requests and responses used for managing the network, transferring data, and synchronizing the states of network components. (3) A specification for the format and relative timing of information exchanged between communicating parties.

R

RAM. Random access memory. (A)

RARP. Reverse Address Resolution Protocol.

register. (1) A storage area in a computer's memory where specific data is stored. (2) A storage device having a specified storage capacity such as bit, byte, or computer word, and usually intended for a special purpose.

remove. (1) To take an attaching device off a network. (2) To stop an adapter from participating in data passing on a network.

ring segment. A ring segment is any section of a ring that can be isolated (by unplugging connectors) from the rest of the ring. A segment can consist of a single lobe, the cable between access units, or a combination of cables, lobes, and/or access units. See *cable segment*, *LAN segment*.

ROM. Read only memory. (A)

S

SCSI. Small computer system interface.

segment. See *cable segment*, *LAN segment*, *ring segment*.

shielded twisted pair. A transmission medium of two twisted conductors with a foil or braid shell.

SMP. System Modification Program

soft error. An intermittent error on a network that causes data to have to be transmitted more than once to be received. A soft error affects the network's performance but does not, by itself, affect the network's overall reliability. If the number of soft errors becomes excessive, reliability is affected. Contrast with *hard error*.

station. (1) A communication device attached to a network. The term used most often in LANs is an *attaching device* or *workstation*. (2) An input or output point of a system that uses telecommunication facilities; for example, one or more systems, computers, terminals, devices, and associated programs at a particular location that can send or receive data over a telecommunication line. See also *attaching device*, *workstation*.

STP. See *shielded twisted pair*.

system. In data processing, a collection of people, machines, and methods organized to accomplish a set of specific functions.

Systems Application Architecture (SAA). An architecture developed by IBM that consists of a set of selected software interfaces, conventions, and protocols, and that serves as a common framework for application development, portability, and use across different IBM hardware systems.

Systems Network Architecture (SNA). The description of the logical structure, formats, protocols, and operational sequences for transmitting information units through, and controlling the configuration and operation of, networks.

Note: The layered structure of SNA allows the ultimate origins and destinations of information, that is, the end users, to be independent of and unaffected by the specific SNA network services and facilities used for information exchange.

T

TCP/IP. Transmission Control Protocol/Internet Protocol. A set of communication protocols that support peer-to-peer connectivity functions for both local and wide area networks.

telephone twisted pair. One or more twisted pairs of copper wire in the unshielded voice-grade cable commonly used to connect a telephone to its wall jack. Also referred to as "unshielded twisted pair" (UTP).

threshold. (1) A level, point, or value above which something is true or will take place and below which it is not true or will not take place. (2) In IBM bridge programs, a value set for the maximum number of frames that are not forwarded across a bridge due to errors, before a "threshold exceeded" occurrence is counted and indicated to network management programs. (3) An initial value from which a counter is decremented to zero, or a value to which a counter is incremented or decremented from an initial value. When the counter reaches zero or the threshold value, a decision is made and/or an event occurs.

token. A sequence of bits passed from one device to another on the token-ring network that signifies permission to transmit over the network. It consists of a starting delimiter, an access control field, and an end delimiter. The access control field contains a bit that indicates to a receiving device that the token is ready to accept information. If a device has data to send along the network, it appends the data to the token. When data is appended, the token then becomes a frame. See *frame*.

Token Ring. A network with a ring topology that passes tokens from one attaching device (node) to another. A node that is ready to send can capture a token and insert data for transmission.

Token-Ring network. (1) A ring network that allows unidirectional data transmission between data stations by a token-passing procedure over one transmission medium so that the transmitted data returns to and is removed by the transmitting station. The IBM Token-Ring Network is a baseband LAN with a star-wired ring topology that passes tokens from network adapter to network adapter. (2) A network that uses a ring topology, in which tokens are passed in a sequence from node to node. A node that is ready to send can capture the token and insert data for transmission. (3) A group of interconnected token rings.

twisted pair. A transmission medium that consists of two insulated conductors twisted together to reduce noise.

U

universally administered address. The address permanently encoded in an adapter at the time of manufacture. All universally administered addresses are unique. Contrast with *locally administered address*.

unshielded twisted pair (UTP). See *telephone twisted pair*.

UTP. See *unshielded twisted pair (UTP)* See also *telephone twisted pair*.

W

W. Watt.

wire fault. An error condition caused by a break or a short circuit in the cable segment that connects the adapter port to its access unit.

Index

A

- adapter
 - installation instructions 5
- AutoSense 51, 63, 75

C

- cables 8
- CD-ROM content 45
- Client 32 35
- client system installation 11
- communication problem, solving 37
- contents, package 2

D

- device driver parameters 51
- device driver problems 43
- device drivers
 - downloading 43
 - from Internet 43
- diagnostics 42
- DOS NDIS 2 25
 - device driver installation 25
 - Novell NetWare Requester (16-bit) 25
- downloading drivers 43
- driver installation instructions 12
- driver problems 43
- drivers 22
 - DOS NDIS 2 installation 25
 - DOS NDIS device driver 25
 - DOS Novell NetWare Requester (16-bit) 25
 - downloading 43
 - from Internet 43
 - installing 12
 - messages 39
 - NDIS 2 23
 - NDIS 2 device driver using MPTS 22
 - NDIS 2 messages 57
 - NDIS device driver 22
 - NDIS3 MAC 28
 - ODI parameters 75
 - OS/2 NDIS device driver 23
 - OS/2 Novell NetWare Requester installation 24
 - parameters 51
 - solving problems with 39
 - Windows NT, installing 26, 27

E

- electronic emission notices 79, 80
- emission notices 80
- EOIDelay 53
- error messages, NDIS device driver 57
- expansion ROM 38
- expansion slot 5

F

- features 1
 - diagnostics 42

- features 1 (*continued*)
 - drivers, installing 12
 - hardware environment limitations 2
 - help with 43
 - labels 41
 - LED states, startup 40
 - LEDs 39
 - management using SNMP 1
 - overview 1
 - problem indications, LEDs 41
 - problems, communication 37
 - software environment limitations 2

G

- green dot label 41

I

- IBM LAN Client 1
- IBM support 43
- inserting the adapter 5
- Installation 1
 - checklist 1
 - DOS NDIS 2 device driver 25
 - DOS Novell NetWare Requester (16-bit) 25
 - driver messages 39
 - in client systems 11
 - in server systems 12
 - instructions for your environment 12
 - messages, driver 39
 - Novell Client DOS/Windows 3.1x 21
 - Novell IntranetWare Client for Windows 95 35
 - Novell IntranetWare Client for Windows NT 35
 - Novell NetWare 3.12 Server 12
 - Novell NetWare 4.11 Server 16
 - OS/2 NDIS 2 device driver 23
 - OS/2 NDIS 2 device driver using MPTS 22
 - OS/2 Novell NetWare Requester 24
 - software 11
 - Windows 95, remote unattended 34
 - Windows 95 drivers
 - with NDIS 3.1 28
 - Windows NT drivers 26, 27
- Internet
 - downloading drivers from 43

K

- kit contents 2

L

- labels 41
- LAN Client 1
 - messages, driver 69
 - parameters, driver 63
 - software 1

LED 40
 problem indications 41
 startup sequence 40
LEDs 39
license agreement 83

M

MAC 41
media access control (MAC) 41
messages
 NDIS device driver 57
MPTS 22
Multiple Protocol Transport Services (MPTS) 22

N

NDIS device driver 22
 manual installation 51
 parameters 51
 version 3.1 with Windows NT 3.51 26
 version 4.0 with Windows NT 4.0 27
 with MPTS 22
 with other programs 23
NDIS device driver protocol 56
NDIS MAC 63
 LAN Client driver 69
 Novell NetWare Server 69
 parameters 63
NDIS MAC parameters 51
NDIS3 MAC driver
 using Windows 95 to install 28
NetWare Client 32 35
network environments 12
notices
 electronic emission 79, 80
 safety ix
 trademarks 78
Novell 12
 DOS NetWare Requester (16-bit) installation 25
 IntranetWare Client for Windows 35
 IntranetWare Client for Windows NT 35
 messages 69
 NetWare 3.12 Server driver installation 12
 NetWare 4.11 Server driver installation 16
 NetWare Requester installation 24
 NetWare Server messages 69
 NetWare Server parameters 63
 Novell Client DOS/Windows 3.1x 21
 ODI driver parameters 75
 parameters 63
Novell IntranetWare Client installation 35
Novell NetWare 3.12 server installation 12

O

ODI driver parameters 75
OS/2 22
 NDIS 2 device driver using MPTS 22
 NDIS 2 device driver using other install
 programs 23

OS/2 22 (continued)
 Novell NetWare Requester 24

P

package contents 2
parameters 51
 datarate 51, 63
 enabletxeofint 51
 frame 63
 fullduplex 52, 63
 llonly 53
 loopback 53
 maxtransmits 51
 maxtxframesize 52
 minrcvbufs 52
 netaddress 51, 52, 53, 54, 55
 node 64
 rcvbufsize 52
 RNICOPEN 64
 rxbuffers 64
 slot 64
 standby 65
 txbuffers 65
 txprimax 53
 txprithresh 53
parameters, device driver 51
parameters, LAN Client driver 63
parameters, Novell NetWare DOS and OS/2 ODI 75
parameters, Novell NetWare Server 63
PCSETUP program 38
placing the adapter 5
problem solving 37
problems with device drivers 43
product support 43
productivity aids license agreement 83
PROTOCOL.INI for DOS 55

R

related publications viii
remote unattended installation
 of Windows 95 34
 of Windows 98 34
 of Windows NT 34
ROM, expansion 38
RT= 65
RTHT= 66
RTSM= 66
RTSWHoldingTime 54
RTSWMode 54
RTSWSubnetMask 54
RTSWTableSize 54
RTTS= 66

S

safety notices ix
server system installation 12
Simple Network Management Protocol (SNMP) 1
slot number in messages 57

SNMP 1
software packages 45
solving problems 39
statement of limited warranty 86
support phone numbers 43
support web addresses 43

T

TCP/IP configuration 55, 56
TCP/IP Version 1.2 for OS/2 23
TCP/IP Version 2.0 for OS/2 23
TCPPortRangeN 55
TPRn= 66
trademarks 78
troubleshooting problems 37
 LED indications 41
TXPRIMAX= 65
TXPRITHRESH 65

U

UDPPortRangeN 55
universally administered address label 41
UPRn= 67
URL for downloading device drivers 43

W

Wake on LAN 6
 signal connector on system board 6
warranty 86
Web Browser 43
Windows 95 28
 installation, drivers 28
 installing NDIS3 MAC driver with 28
Windows NT 26
 Version 3.51 with NDIS 3.1 installation 26
 Version 4.0 with NDIS 4.0 installation 27